



**E2**  
**SYSTEMS**

**EN**

## **Manual**

Electro Hydraulic Drilling  
And Tapping Unit

Series BE 55 and BEG 55



Read this manual before installation and  
commissioning of the product.  
Keep for future reference.

MAN055 - Manual BE 55 and BEG 55, EN, ORIGINAL, Rev.  
02.doc

**E2 Systems**

A DIVISION OF TUBEX AB

Strömslundsgatan 3 SE-50762 Borås Phone +46-(0)33 20 88 40 Fax +46-(0)33 20 88 49  
E-mail e2@e2systems.com www.e2systems.com V.A.T. no SE556396841001



**DECLARATION OF INCORPORATION OF  
PARTLY COMPLETED MACHINERY  
ORIGINAL**

**According to the EC's Machinery Directive 2006/42/EC, Annex 2B**

We,

E2 Systems a division of Tubex AB  
Strömslundsgatan 3  
507 62 Borås  
Sweden,

declare that the partly completed machine:

**Model: BE55X or BEG55X**

\* Is designed to be embedded in a larger machinery or assembled with another machine, which together will constitute machinery covered by Directive 2006/42/EC "Machinery Directive" and which shall be constructed in compliance with this directive, and

\* Must not be put into service until the machinery, which the partly completed machinery must be part of, has been found and thus as a whole is declared in accordance with the "Machinery Directive" and national legislation. We also confirm:

\* That the item 1 and 2.3 from the "Machinery Directive" Annex 1 concerning essential health and safety issues in the design of machines, which are reported in the manual for the above partly completed machinery, have been performed, and

\* That the relevant technical documentation is compiled in accordance with Annex 7, Section B of the Directive 2006/42/EC

At the substantiated request of national authorities will relevant documents on the partly completed machinery be handed over.

Following other directive

2004/108/EC Electromagnetic Compatibility (EMC)

and harmonized standards, including appendix, has been applied:

EN ISO 12100:2010 Safety of machinery -- General principles for design -- Risk assessment and risk reduction.

SIS ISO TR 14121-2:2007 Safety of machinery -- Risk assessment -- Part 2: Practical guidance and examples of methods.

SS EN ISO 4413:2010 Hydraulic fluid power -- General rules and safety requirements for systems and their components.

SS EN ISO 60204-1 Safety of machinery - Electrical equipment of machines - Part 1: General requirements

Borås: 2009-12-18



Krister Johansson  
CEO Tubex AB



Andreas Gabrielsson  
responsible for the technical file

<b>Table of content:</b>	<b>Page:</b>
Table of content	4
Safety	5
Information about manufacturer	6
Device management	6
Description of the Drilling and Tapping unit	7
Installation	8, 9, 10, 11
Start-up	12
Settings	13
Tool holders and Cutting tools	14
Coolant feed through spindle for BE 55 with ER32/MT2 chuck	14
Drilling, counter sinking and reaming	15
Tapping	16
Maintenance instructions	17, 18, 19
Hydraulic oil change	20
Recommended hydraulic oils	20
Hydraulic diagram and components	21
Control card C1:A and wiring diagram	22
Technical information	23
Dimensional drawing	24
Spare parts drawing, general	25
Spare parts list, general	26, 27, 28, 29, 30, 31
Spare parts drawing and spare parts list, Feed housing	32, 33, 34
Spare parts drawing and spare parts list, Hydraulic, pump and coupling	35
Spare parts drawing and spare parts list, Valve block	36
Spare parts drawing and spare parts list, Transmission	37, 38, 39, 40, 41
Spare parts drawing and spare parts list, Transmission housing	42
Spare parts drawing and spare parts list, Control card C1:A	43
Warranty conditions	44
Environmental declaration	44



### **WARNING!**

- Ensure that the operator has read and understood this manual before the drilling unit is in use.
- For security reasons, any modification of the drilling/tapping unit and its accessories, which may affect product safety, must be approved by the manufacturer's technical manager.
- The unit is intended for drilling, countersinking, reaming and tapping and should not be used for any other application, unless approved by the manufacturer's technical manager.
- Always follow local security regulations regarding installation, operation and maintenance.
- The unit must be securely fixed and the installation instructions must be strictly observed.
- The drilling/tapping unit must be protected against splash of emulsions, etc. This is to protect the units control system and ensure the units function.
- When installing the unit on a stand or in a complete machine tool, necessary protective devices must be fitted to prevent injury caused by crushing (squeezing) or any other type of personal injury that might be caused by the unit or its rotating tool.
- All protective devices that are designed to prevent personal injury must be mounted in their intended position during the operation.
- When servicing or repairing the unit, the electrical system must be switched off and the hydraulic system depressurized.
- Beware of hands, gloves, hair and loose fit clothing – Watch out for rotating parts.
- Never operate the unit without any eventual safety arrangements – Beware of risk for crushing.
- Make sure that all hoses and electrical wires are safely fastened – Beware of risk for crushing.
- Ignoring the instruction may invalidate the warranty.

**More detailed information regarding risks related to the unit described below.**

According to Machinery Directive 2006/42/EC the unit is a "partly completed machine". Thereby the manufacturer of the machine is responsible for the overall safety. This device should not be operational within EU before the machine, in which the device must be integrated in, assured to meet the Machinery Directive 2006/42/EC. This manual is developed according to Machinery Directive and also includes additional information to make it easy for the manufacturer of the machine to meet the Machinery Directive and the end user to maintain a high level of security

The machine is intended for use by a person with knowledge and experience of using a machine of this type, and without limited physical ability in arms and hands as well as fully sighted. The machine is designed to be serviced by a trained / qualified operator following the instructions provided in the manual. The accidents that are likely still might occur is when the machine is running without protection or with inadequate protection, without a fence, clamps or jigs. Ill health may arise from issues or material used, for example:

- Noise generated during the drilling / threading;
- Drilling dust / chips;
- Fumes and substances released during drilling of impregnated or treated material.

### **General recommendations according to the above**

- Apply a system for monitoring the tool in the machine. If no such system is at hand, we recommend user/operator to frequently control the tool. To ensure that no damages occurred.
- Secure that electric motor is supplied with overload protection.

### **Thorough review of the unit**

Visual control of any external damages. Ensure there is possibility to quickly turn off the motor and air-supply and run a normal cycle without tool and material (to avoid further damages at the material and unit). Listen for noise from bearings and also control the run-out at the spindle nose. If not ok, unit has to be repaired and a new control for damages will be necessary. If a unit seems ok, perform a normal cycle and evaluate the processed result.

### **If accident or breakdown occurs:**

When accident or breakdown occurs as results in damages, or risk for accident, should the unit be transferred to workshop or similar to ensure that unit can be repaired in a safe place. An accident or breakdown will assume that the entire machine is affected. Therefore is it up to the machine supplier to describe the work method when accident or breakdown occurs. E2Systems will with this manual make it easy to achieve a safe design of the machine.

## **Information about the manufacturer**

Drill and thread unit is manufactured and supplied by E2 Systems a division of Tubex AB. E2 Systems are specialized in constructing and manufacturing drill and thread units. The units are compact and have a robust design constructed to be easy to use and have a long life-span with high precision. More of E2 Systems collection you will find at [www.e2systems.com](http://www.e2systems.com). If you would like to come in contact with E2 Systems regarding questions or comments on our products or documentation, our contact information follows:

E2 Systems

Strömslundsgatan 3

507 62 BORÅS

Telefon: 033-20 88 40

Fax: 033-20 88 49

E-mail: [e2@e2systems.com](mailto:e2@e2systems.com)

## **Device management**

The BE(G)55-series weight in most cases between 25-35kg and always lesser than 51kg (BE558 with largest possible multi-spindle head VH184D). Which means that units should be carried with two persons standing towards each other and walking sideways? All models should be carried in minimum 2 attachment points, both considering the safety for the persons lifting the unit and also considering the safety for the unit. Hands as well as other lifting devices which are used as carrying device should be attached at feeding house/-control (to the left on drawing in the end of the manual) in front of the unit as well as transmission housing at the units rear position (to the left at drawing) to ensure best possible grip and balance of weight. The unit can be lifted around the electric motor as one lifting point if it is done carefully and for a shorter time. The same applies for the spindle/chuck for units with integrated ER chuck or mounted multi-spindle head.

BE(G)55- series weight is laterally symmetric, but not in any other direction. Because of unit compact laterally it may, with the engine in the standard mode up, easily obtained from tipping sideways from a stable standing position. There is a risk for squeezing damages and other not direct damages occurring from the heaviness from the falling unit. Therefore should the unit be mounted or put in sideways position before installing adjustments of electric motor and pneumatic air. When motor are mounted in 90° degree are unit stabile standing. When the unit are mounted in 180° degree should the unit be placed on a surface which the motor can be hanging outside table edge. Therefore should the unit always be placed as long from the edge possible.

## Description of the Drilling and Tapping unit

The **BE 55** series is a powerful and yet compact electro-hydraulic drilling unit of a modular design. The electric motor runs the spindle while the feed is both hydraulically powered and controlled. The hydraulic feed control together with position switches make it possible to include functions such as multi wall drilling, peck drilling, rapid advance and automatic chip removal.

The **BEG 55** series is a powerful and yet very compact electro-hydraulic tapping unit of a modular design. The electric motor runs the spindle while the feed is both hydraulically powered and controlled. A tapping spindle gives the unit the necessary length compensation. The hydraulic feed control together with position switches makes it possible to include functions such as rapid advance.

Type and speed: See data label on unit  
Serial number: See data label on unit

E2 SYSTEMS		Made in Sweden	
Type		Ser. No	
BE 552		090301	
	2820		rpm

1. Spindle with MT2 or JT2 taper.
2. Setting screw for stroke length limit.
3. Pinole
4. Electric motor. Forward or backward mounted.
5. Transmission housing with transmission between electric motor and drive shaft.
6. Hydraulic valve block.
7. Solenoid valves.
8. Hydraulic gear wheel pump, reversible.
9. Feed housing.
10. Clips sensor with clip ruler and clips.
11. Mid section.
12. Electronic box with control system.

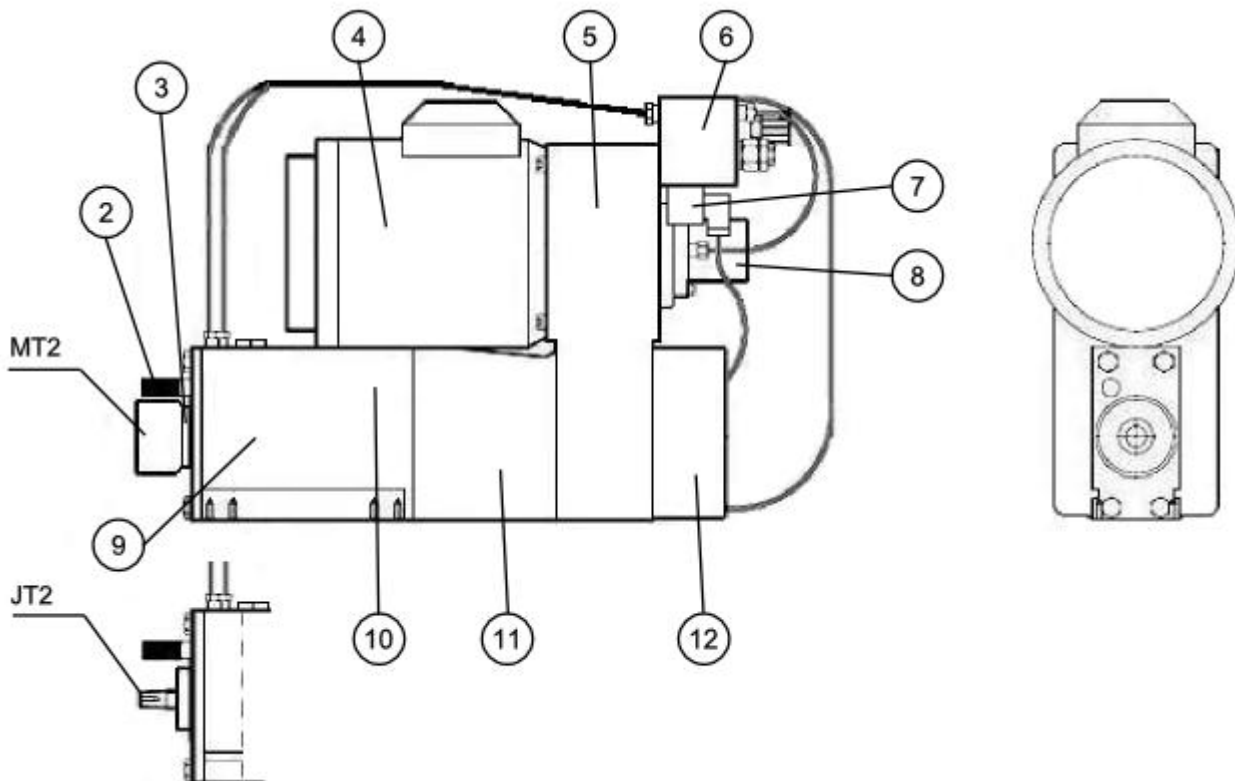



## Installation

This Drilling and Tapping Unit is only intended for use in machinery which applies to the Machine Directive 2006/42/EC. This Drilling and Tapping Unit is designed for normal drilling, countersinking, reaming and tapping. In applications requiring high-precision hole placement or when drilling into rounded or slanted surfaces, drill bushings must be used.

To be able to use the unit, it must first be installed and fitted with control equipment. Regardless of how simple the installation is performed, the unit must be fitted with necessary protective devices to avoid personal injury. Special precaution must be taken to eliminate the risk of clothing, gloves, hair, etc. being caught in the rotating tool. The unit should always be mounted to a flat surface and be attached to a stable construction. Avoid adjacent parts enhancing resonance noise and vibrations wherever it is possible, which can create a resonance box effect.

The unit consists of many components and preassembled parts, the reliability of which is dependent upon proper maintenance. The pneumatic and hydraulic systems include a number of seals. It is essential to keep moving seal surfaces clean and free of marks and scratches



### WARNING!

Never use the unit without being securely fastened and that appropriate security arrangements have been organized.

Be careful with rotating and moving parts, to avoid personal injuries.

Ensure that the unit is disconnected from the main air-supply, before any maintenance.

If the user feels the need to control the operation of this unit before it is installed in the machine, this is done **AT YOUR OWN RISK**

If test will be done anyway beware of following risk

Attached the unit to something very stable

Keep hair, clothes and other loose things away from the rotating spindle.

Keep everything away from spindle when feeds forward and back – for risk for clamping

Give space so that the feeding can feed all stroke (100mm) add safety distance for clamping risk

1. We recommend that this unit is installed in a place with clean air and an ambient temperature of +10 - +40° C (+50 - +104 F.).
2. The unit must not be exposed to vibrations.
3. The control system may not be exposed to direct spraying of water, coolant or the like.
4. The unit must always be mounted on a flat surface (machined) and attached with belonging brackets or own arrangements. See Fig 1a and Fig 1b.

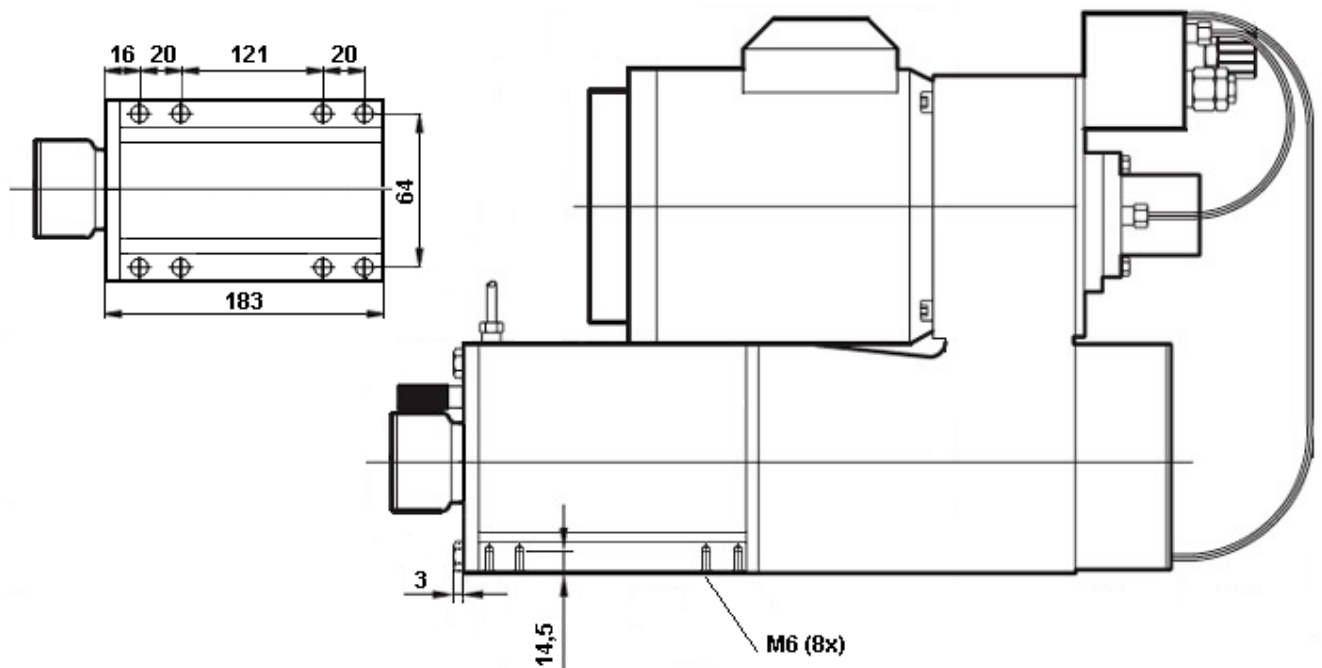

Fig. 1a.



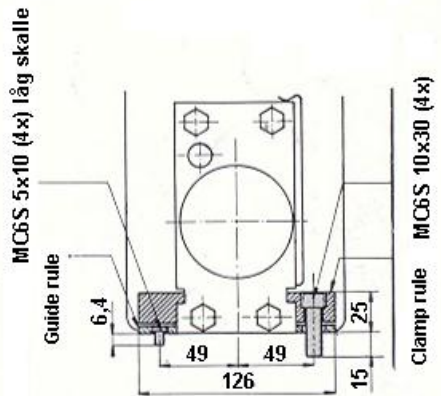
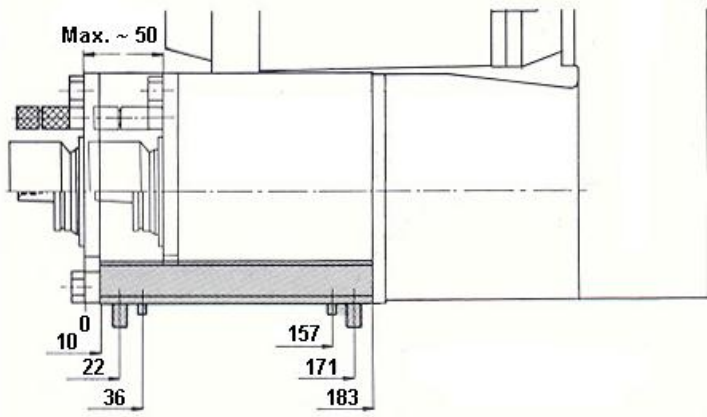
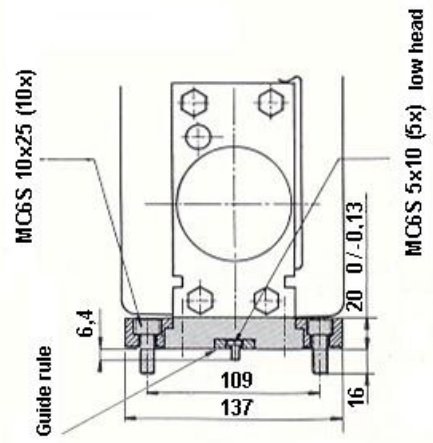
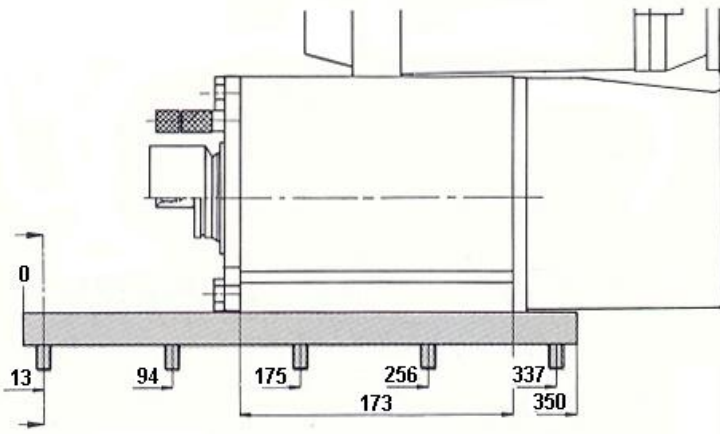

Fig. 1b.

5. Connection of the electric motor is done as shown in Fig. 2. and depending on which 3-phase voltage is available. Check all the data on the electric motors data label to ensure that motor protection and connection are properly carried out. The electric motor must be equipped with a suitable control circuit and motor protection. Different brands of motors may be present. See the enclosed manual from the engine manufacturer, and follow its installation instructions. Specifically for this unit: The connection cable must have an area of at least 1.5 mm<sup>2</sup>. Ensure that the motor rotation direction is correct.

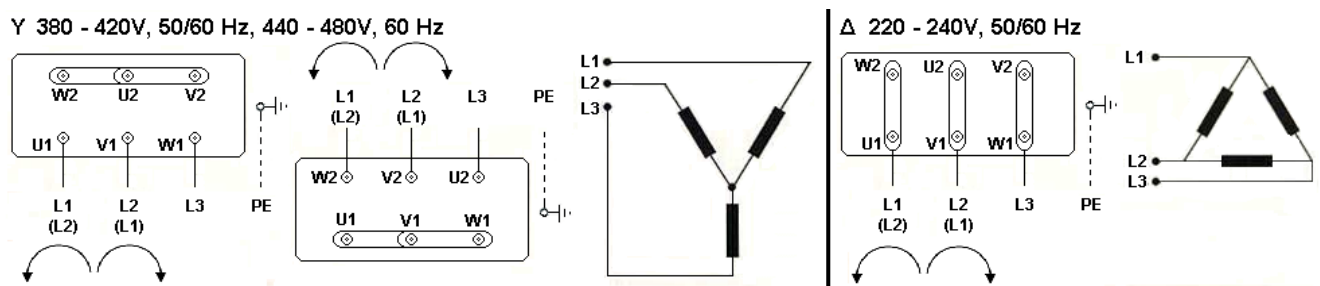
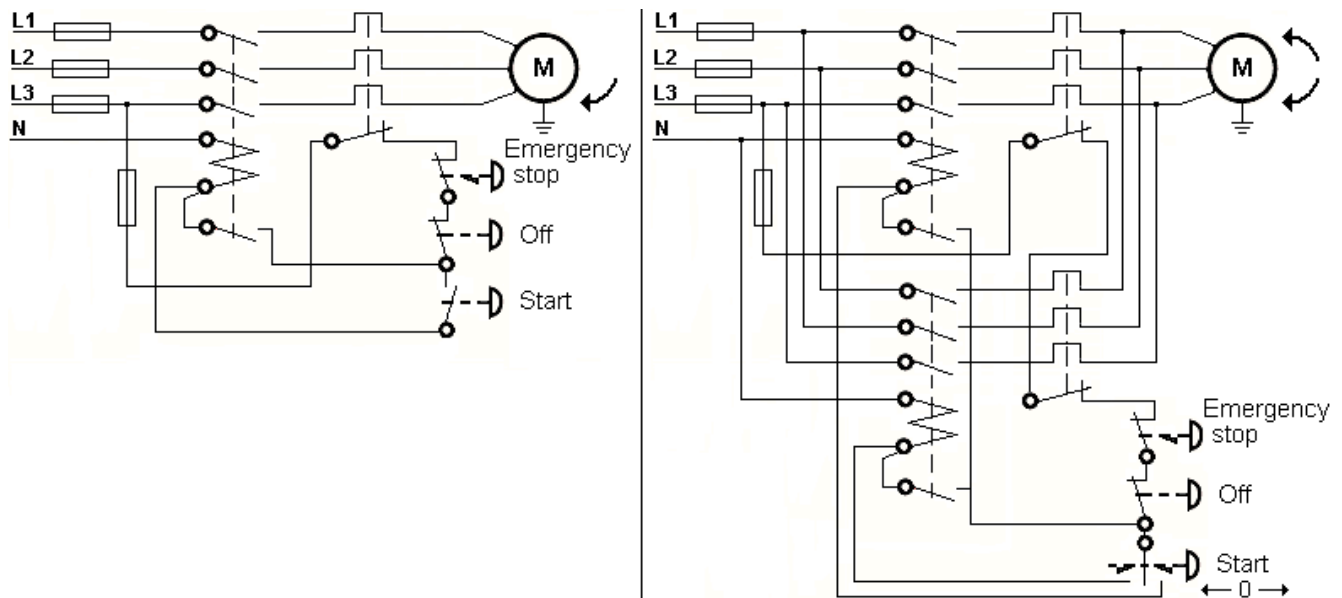

Fig. 2.

If the phases L1, L2 and L3 are connected to the terminals as shown in Fig. 2 the motor shaft rotates clockwise, seen against the shaft end on the drive side. Let two of the phase cables change place if the direction of rotation needs to be changed.

Example of control circuit: One way rotation for drilling and two way rotation for tapping.



6. Connection of the power supply to the control system. See Fig. 3.

(A) Control card C1:A is supplied with either 220 VAC or 110 VAC  $\pm$ 15V.

(B) Control card C1:A is supplied with 24 VDC (From the external control system, PLC.).

(C) and (D) Solenoid valves A and B are connected to the control card at factory.

### Interface C1:A

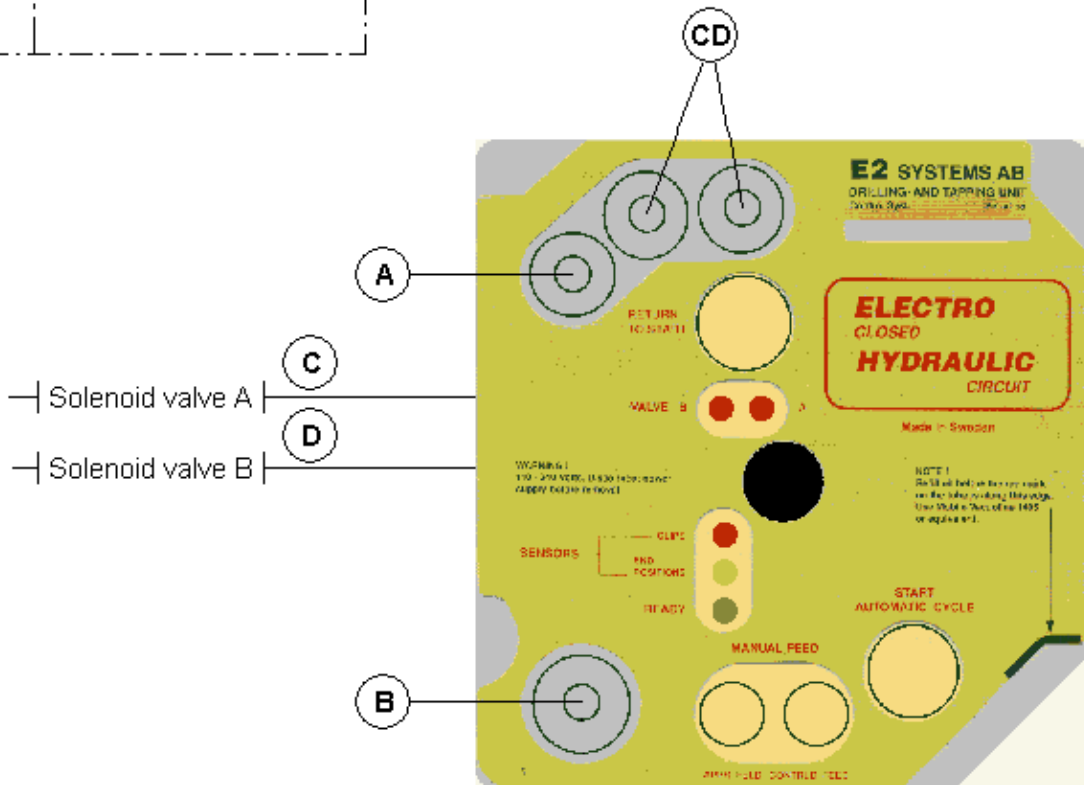
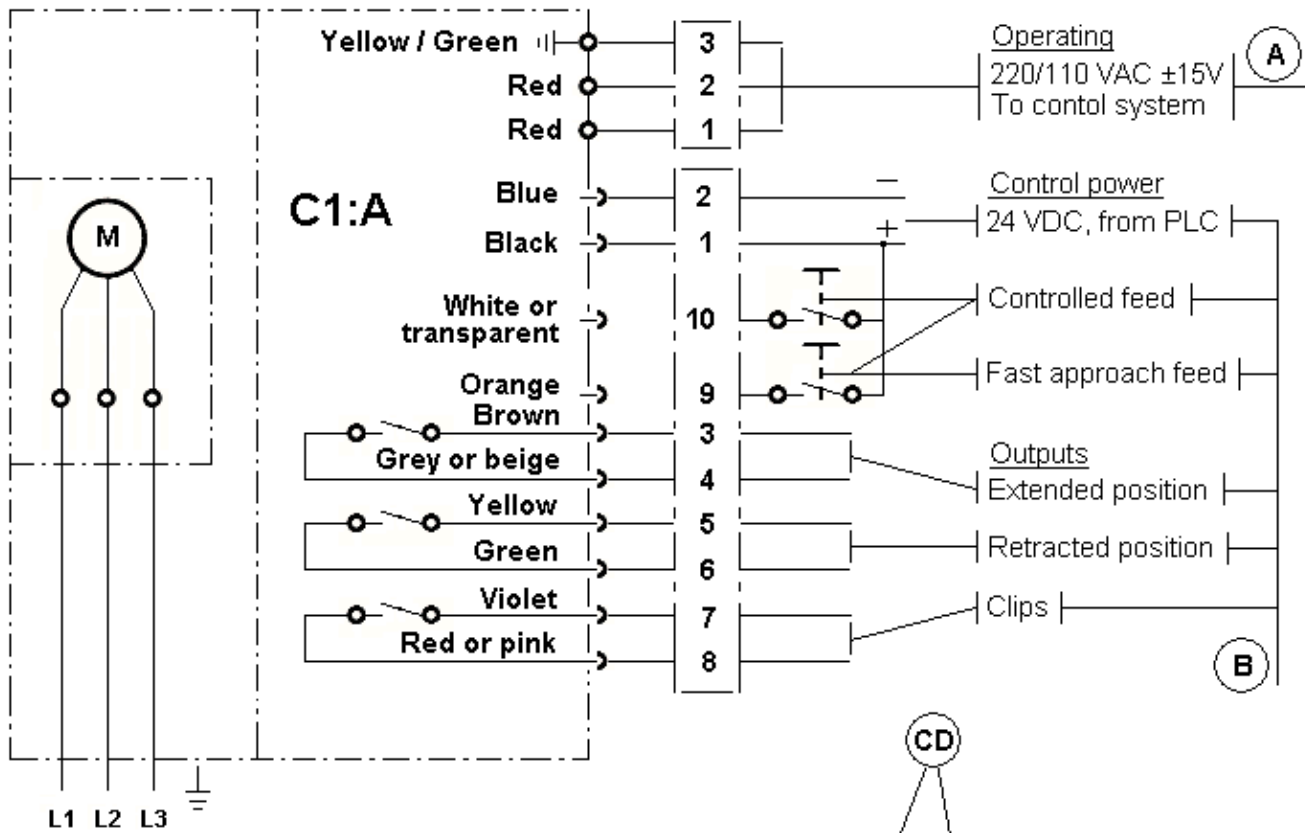

Fig. 3.

## Start-up

1. Ensure that the responsible operator has read and understood the manual before start-up of the unit.
2. Ensure that the unit's safety in paragraph "Security" is met before starting the unit.
3. Possible local safety regulations must be followed.
4. Ensure that the installation of the unit is performed as described in paragraph "Installation".
5. Check that the unit's hoses and cables have not been damaged during shipment or installation.
6. Check the unit so that no other damage has occurred, which may cause oil leakage.
7. Start the electric motor and immediately check that it runs in the right direction and that the drill spindle in the right direction for drilling.

**NOTE!** Some units for tapping are provided with a valve block for the function of reversing the electric motor.

8. Press the push-button for working feed "**CONTRLD FEED**" (located on the unit's control system, "**MANUAL FEED**") and hold it there. When the push-button is released the spindle returns to its rear end position.
9. This procedure is repeated with approach feed "**APPR. FEED**".
10. Check that the green LED lights when (located on the control system) the drill spindle is in its rear end position, "**READY**".
11. Check that the red LED lights when (located on the control system) the drill spindle is in its front end position, "**END POSITIONS**".
12. Check that there are clips on the clip ruler and (located on the control system) the clip LED lights when a clips is passing the clips sensor, "**CLIPS**".

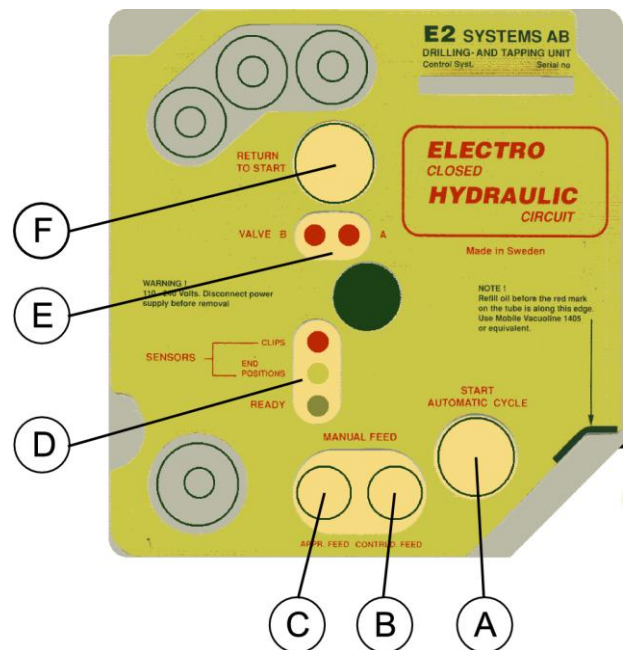

Fig. 4

### The control panels push-buttons and functions.

- A. "**START AUTOMATIC CYCLE**". Push-button for start of automatic cycle.
- B. "**MANUAL FEED**" / "**CONTROLLED FEED**". Push-button for manual operation of the spindle with controlled feed.
- C. "**MANUAL FEED**" / "**APPR. FEED**". Push-button for manual operation of the spindle with approach feed.
- D. "**SENSORS**" / "**CLIPS**". Red LED, for indication of activation (signal) for clips sensor. "**SENSORS**" / "**END POSITION**". Yellow LED, for indication of spindle in end position. "**SENSORS** / **READY**". Green LED, for indication of spindle in ready position.
- E. "**VALVE B A**". Red, LED for indication of activation for solenoid valves A and B.
- F. "**RETURN TO START**". Push-button for return to end position.

## Settings

### **Thrust force "LIMITATION OF FEED THRUST":**

The thrust force for the units spindle is adjusted with knob "A". On top of the valve block is a table with dimensions for different settings of the thrust force.

- Set a caliper to the desired dimension of the desired thrust.
- Then adjust the knob "A" until the desired dimension measured.

Clockwise adjustment provides increased and anti-clockwise adjustment provides reduced thrust.  
Max. thrust is 6000 N.

### **Working feed "CONTROLLED FEED":**

The working feed rate is adjusted with knob "B". Clockwise adjustment provides reduced and anti-clockwise adjustment provides increased working feed rate.  
Min. and max. working feed rate is between 0,04 – 0,65 m/min (1.6 – 25 In/min.).

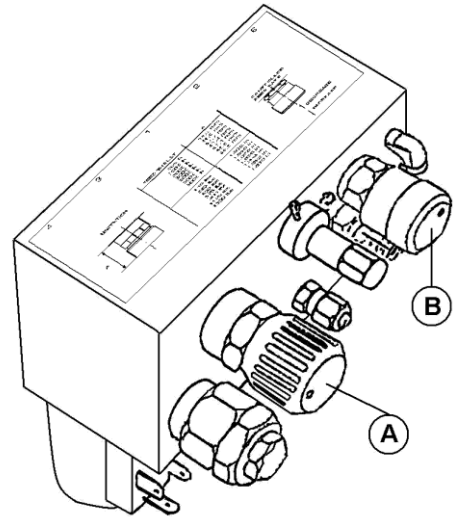

### **Rapid advance "APPROACH FEED": "RAPID ADVANCE RATE"**

The rapid advance feed rate is set by setting screw "C". Clockwise adjustment provides reduced and anti-clockwise adjustment provides increased rapid advance rate.  
Max. rapid advance rate is 6 m/min (230 In/min).

### **Retract feed "RETRACT FEED":**

The retract feed rate is set by setting screw "D". Inwards adjustment provides reduced and outwards adjustment provides increased retract feed rate.  
Max. retract feed rate is 6 m/min (230 In/min).

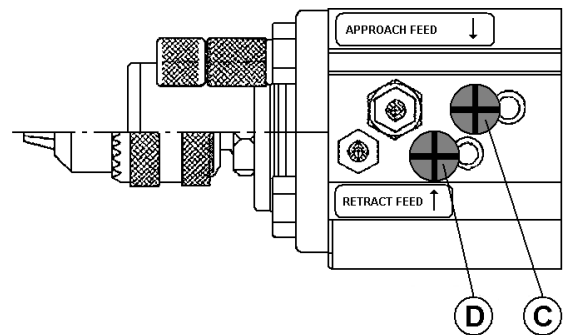

### **Feed depth "STROKE DEPTH":**

The feed depth is set by setting screw "F". Clockwise adjustment provides shorter and anti-clockwise adjustment provides longer feed depth.  
1 revolution corresponds to 1 mm (.039") feed depth.  
Adjustment screw "F" is locked with locking nut "G".

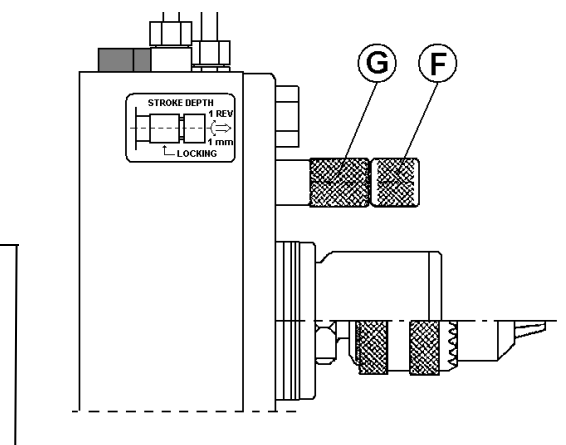

### **The working feed start position:**

Clips sensor "H", clip ruler "I" and clips "J".

The unit comes with 3 pcs clips. One clip must be mounted on the clip ruler "I" for the desired starting position of working feed.

If desired, other functions can be controlled via clips sensor "H". Several clips can be mounted on the clip ruler.

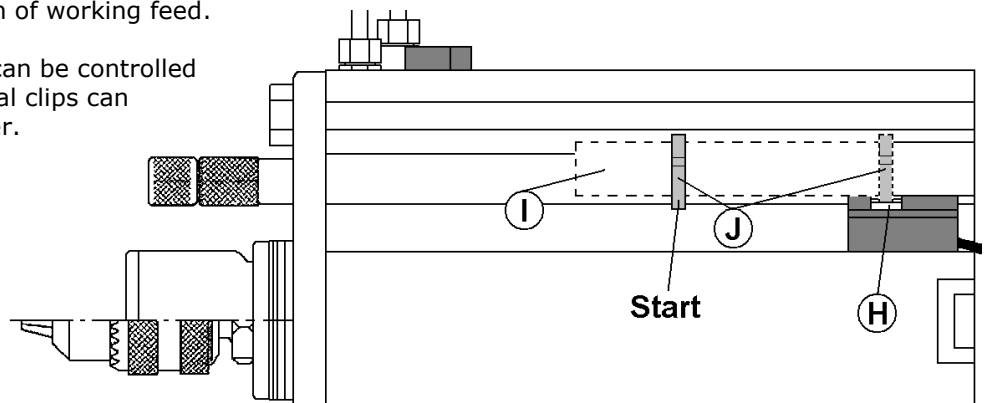

## Tool holders and Cutting tools

The unit can be equipped with the following tool holder types: (Chosen when ordering.)

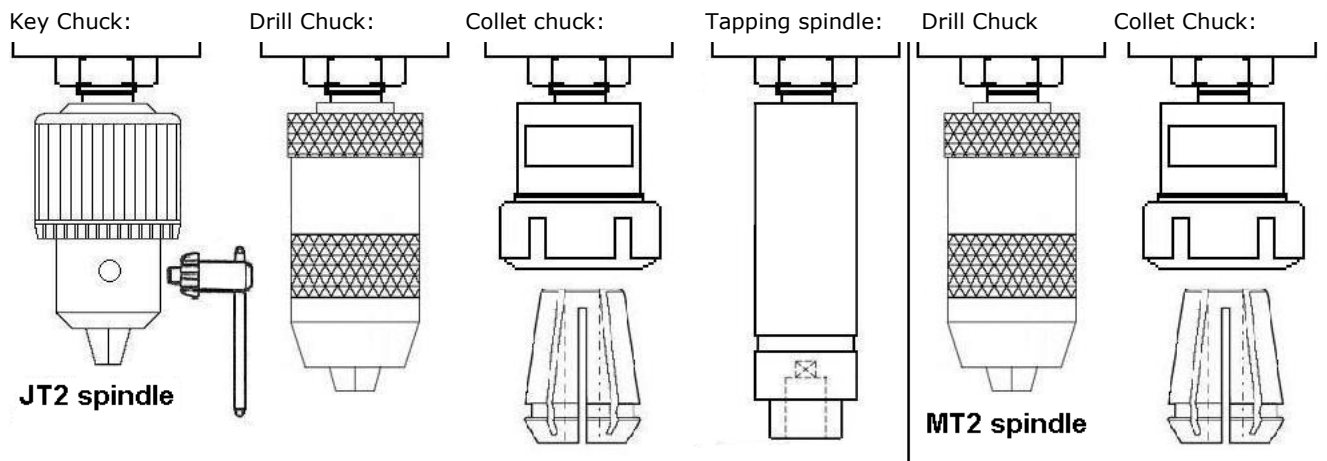

The following cutting tools can be used with drilling or tapping unit:

Drilling unit BE 55: Drills, Core Drills, Shank Mills, Counter sinkers or Reamers.  
Tapping unit BEG 55: Cutting Taps or forming Taps.

## Coolant feed through spindle for BE 55 with ER32/MT2 chuck

The ER32/MT2 collet chuck to be used is of special design to seal around the drill.

- Max. pressure 70 Bars (up to 3000 rpm). Operation at max pressure with max speed is not permissible.
- Max. speed 7000 rpm (at pressure 40 Bars).
- Straight shaft drills with internal cooling fitting in an ER32/MT2 chuck.  
Ranges from Ø5 - 20 mm (3/16 - 13/16").
- Drills with internal cooling ranges from Ø1,5-4 mm (.05 - .157") (Ø5 mm (3/16") on request).

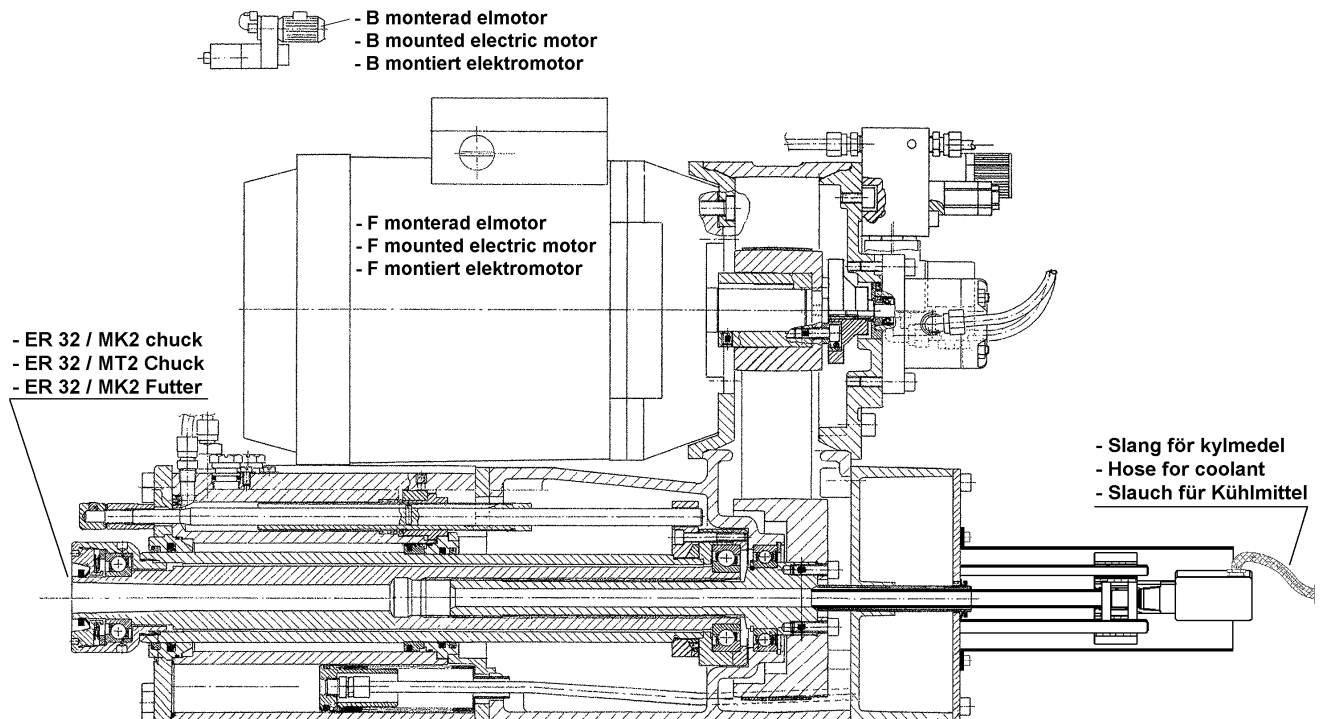



## Drilling, counter sinking and reaming

1. Open the regulating valve for the feed thrust marked "**LIMITATION**", knob "**A**", on the valve block.
2. Set the desired drilling depth by setting screw "**F**" located at the front of the feed housing. Set depth is locked with lock nut "**G**".
3. Measure the length of feeding (drilling depth) carefully ..... mm (inch).
4. According to table of feed rates, the feed rate shall be ..... mm/s (inch/sec).

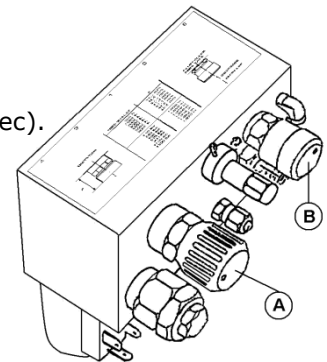

5. Calculate the time it takes for the spindle to move the entire feed length, use a stop watch:

$$\text{Time} = \frac{\text{Feed length in mm (inch)}}{\text{Feed rate in mm/sec (inch/sec)}} = \text{..... Sec}$$

6. Open or close the regulating valve marked "**CONTROLLED FEED RATE**", knob "**B**", for working feed rate until the time is the same as calculated in paragraph 5.

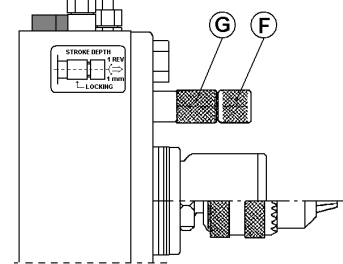

7. The drilling can now start in the intended material.
8. When the drill or the drills reaches the material, begin to adjust the feed thrust rate, this is done with knob "**A**". Adjust until the preset feed thrust is obtained.
9. To obtain a constant feed rate even when the drill begins to become worn, regulating valve, knob "**B**", can be screwed in 1 revolution extra.

**Note!** In automatic cycle mode the drilling depth is 0,4 mm (.015") shorter than for manual feed.

10. Remove the protection plate on the feed housing and press the push-button for approach or controlled feed. The clip ruler comes out of the transmission housing.

When the clip ruler "**I**" is in its front position, clips "**J**", can be placed on the clip ruler where the unit shall enter into work feed and vice versa.

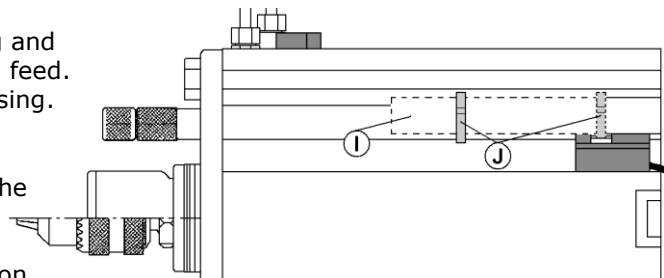

11. When the spindle has been in its front end position and returned to the start position "**READY**" signal is indicated.

13. The rapid advance feed rate of the spindle is set by the throttle-valve located at the front of the feed housing marked "**APPROACH FEED**", setting screw "**C**".

14. The retract feed of the spindle speed is set by the throttle-valve located at the front of the feed housing marked "**RETRACT FEED**", setting screw "**D**".

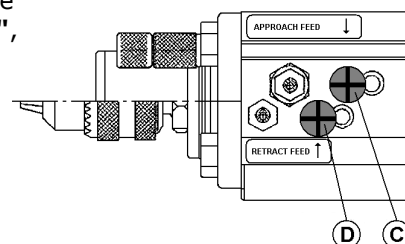



# Tapping

Tapping can be performed with a reversible tapping head or by reversing the unit's electric motor.

**Note!** When reversal of the units electric motor, an axial floating tapping spindle must be used.

1. The regulating valve for thrust feed marked "**LIMITATION**", knob "**A**", is set to as low thrust feed as possible.
2. Set the desired tapping depth by setting screw "**F**" located at the front of the feed housing. Set depth is locked with lock nut "**G**".
3. Measure the length of feeding (tapping depth) carefully ..... mm (inch)
4. Use the following formula to calculate the feed rate:

$$\text{Feed rate} = \frac{\text{Rpm/min}}{60} \times \text{thread pitch} = \dots\dots\dots \text{mm/s (inch/sec)}$$

5. Calculate the time it takes for the spindle to move the entire feed length, use a stop watch:

$$\text{Time} = \frac{\text{Feed length in mm (inch)}}{\text{Feed rate in mm/sec (inch/sec)}} = \dots\dots\dots \text{Sec}$$

6. Open or close the regulating valve marked "**CONTROLLED FEED RATE**", knob "**B**", for working feed rate until the time is the same as calculated in paragraph 5.

**Note!** When the feed rate is insufficient the rapid feed rate is used, which is reduced down to the right speed by the throttle-valve located at the front of the feed housing marked, "**APPROACH FEED**", setting screw "**C**".

**Note!** The spindle feed rate must be somewhat lesser than the axial speed of the tap. The difference in distance is absorbed by the reversible tapping head or the axial floating tapping spindle which must be used when reversal of the units electric motor.

7. The retract speed of the spindle must always be adjusted by the throttle-valve located at the front of the feed housing marked "**RETRACT SPEED**", setting screw "**D**".

**Note!** The retract rate when using reversible tapping heads should be slightly higher than the taps axial retract rate.

**Note!** When using axial floating tapping spindle, the spindle retract feed rate should be as close to the taps axial speed as possible, the difference in distance is absorbed by the floating spindle.

8. The tapping can now start in the intended material.
9. Remove the protection plate on the feed housing and press the push-button for approach or controlled feed. The clip ruler comes out of the transmission housing.

When the clip ruler "**I**" is in its front position, clips "**J**", can be placed on the clip ruler where the unit shall enter into work feed and vice versa.

10. When the spindle has been in its front end position and returned to the start position "**READY**" signal is indicated.

11. The rapid advance feed rate of the spindle is set by the throttle-valve located at the front of the feed housing marked "**APPROACH FEED**", setting screw "**C**".

12. The retract feed of the spindle speed is set by the throttle-valve located at the front of the feed housing marked "**RETRACT FEED**", setting screw "**D**".

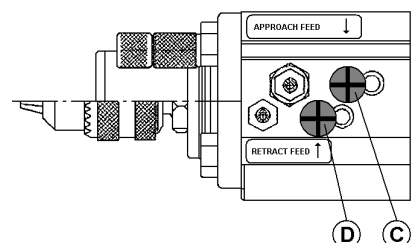
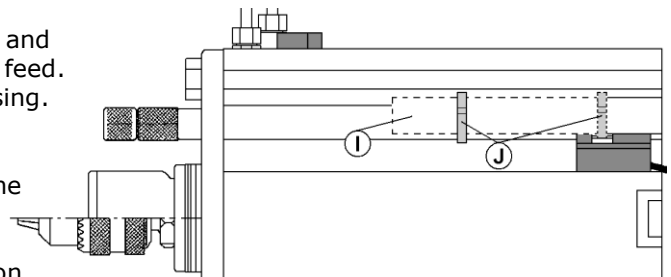
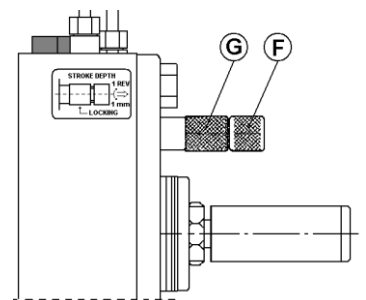
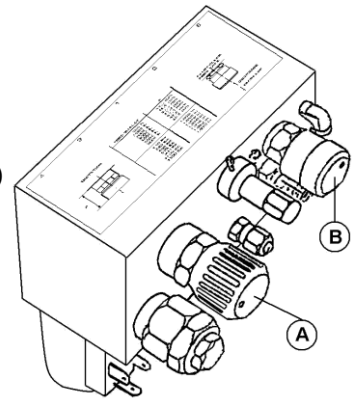

## Maintenance instructions

### **Daily inspection:**

1. Ensure that the unit is free from chips and dirt that can cause malfunctions.
2. Ensure that the unit operates smoothly and that no dissonance exists. In the event of discords or other disturbances stop the operation immediately and call for service personnel to fix the error as soon as possible.
3. Check that the unit is functioning properly with regard to;
  - Smooth operation of the feed spindle
  - Sound level
  - Oil temperature
4. Check that no oil leakage and that no hoses are damaged. If the event of leakage immediately stop the operation and call the service personnel. At leakage check the oil level in accordance with chapter "Monthly inspection", paragraph 1. Call for service personnel to fix the leak as soon as possible.

### **Monthly inspection:**

1. Check the oil level;
  - Electronic box rear edge of box (see arrows). The oil level should be between the green and red marking of the hose to the tank piston. if oil refilling is required, see paragraph "Hydraulic oil change".
2. Check the condition of the oil regarding;
  - Air bubbles
  - Color (if the oil is black, change the oil)
3. Check the locking of the settings regarding;
  - Drill depth
  - Thrust
  - Controlled feed rate

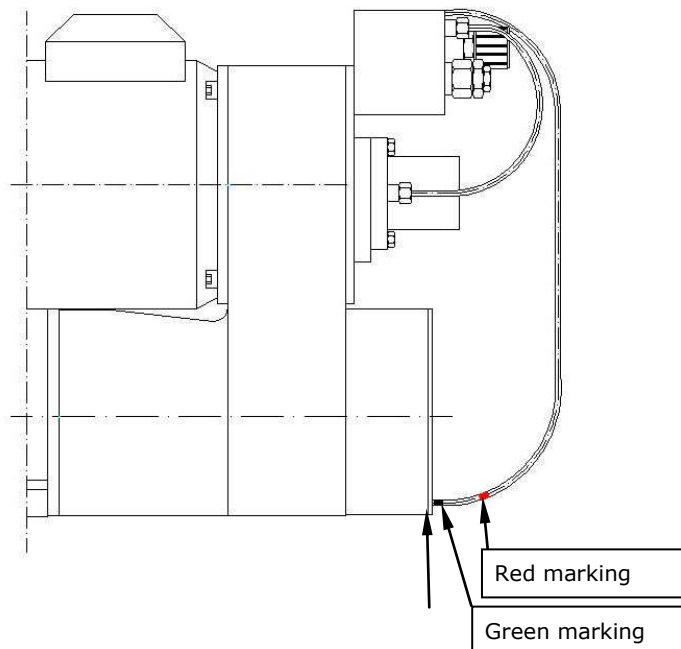

## **Annual inspection:**

Change of return filter "E", pressure filter "F" and oil.

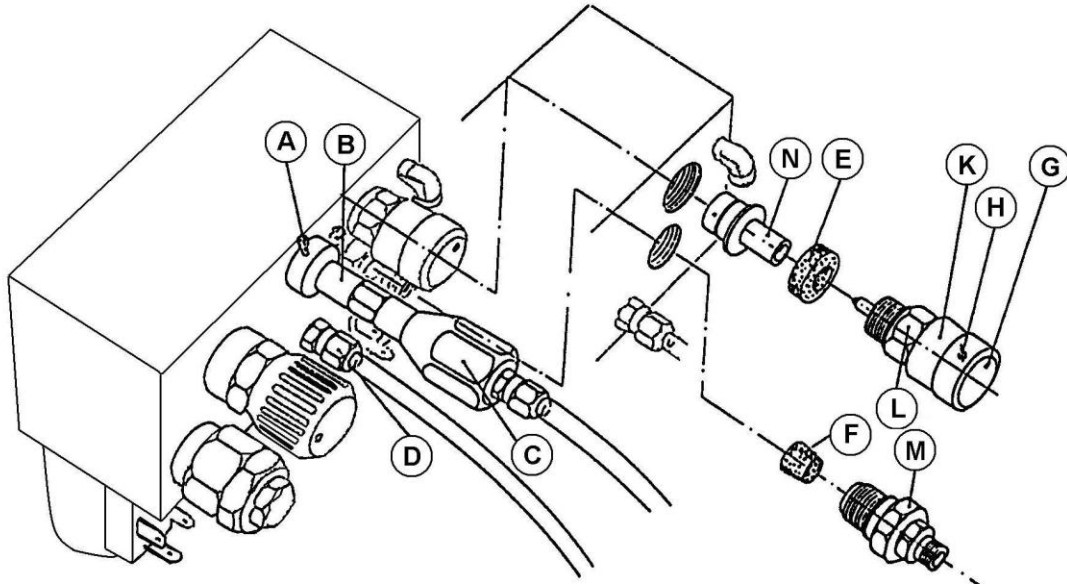

1. Instead of valve "C" (See chapter, "Hydraulic oil change", paragraph 1), connect the "third" supplied hose.
2. Connect hose "D". **Important!** Tighten the coupling so that air is not drawn into the hydraulic system.
3. Put the two hose ends in a vessel for the collection of the waste oil.
4. Unscrew the locking screw "A" and pull the valve sleeve "B" to its outer position, to drain the oil from the oil tank. The red marking should reach the rear edge of the electronic control box. See chapter, "Monthly inspection", paragraph 1.
5. **Change of pressure and return filter:**
  - Loosen locking screw "G".
  - Loosen grub screw "H".
  - Screw of knob "K".
  - Remove valve adaptor "L".
  - Loosen the locking nut on the hose coupling to filter adaptor "M".
  - Remove adaptor "M".
  - Change pressure filter "F" placed inside adaptor "M".
  - Put back adapter "M" and reconnect the pressure hose.
  - Pull out reduction seat "N". **Note!** Be careful not to damage the hole when removing the reduction seat.
  - Change return filter "E".
  - Put back reduction seat "N" in the valve block.
  - Put back valve adaptor "L" in the valve block.
  - Screw on knob "K" completely.
  - Secure knob "K" with grub screw "H".

## 6. Refilling the hydraulic system with oil.

See chapter, "Hydraulic oil change".

## 7. Inspection of the drive belt and pump coupling.

- Remove the two connectors **"A"** from the solenoid valves.
- Loosen the screw **"B"** for attachment of the valve block to the hydraulic lid.
- Loosen the four screws **"C"** for attachment of the hydraulic lid to the transmission housing.
- Expose the drive belt **"D"** by moving the hydraulic lid and valve block to the side.
- Check the drive belt **"D"** for wear and other eventual damages.

In the event of wear or other damage, replace the drive belt:

- Loosen the four screws **"E"** for the attachment of the electric motor, but not completely.
  - Lift the motor slightly upwards so that the drive belt can be detached.
  - Replace the drive belt.
  - Put back the electric motor and tighten the four screws **"E"**.
  - Make sure the drive belt has been correctly fitted.
  - Reassemble the hydraulic lid and valve block. Check that the pumps shaft coupling and the electric motor coupling are fitted in correctly.
- Check the pump couplings shaft gasket **"F"** (radial gasket) regarding leakage, wear and other eventual damage. In the event of leakage, wear or damage, replace the shaft gasket.

In the event of leakage, wear or damage, replace the shaft gasket:

- Loosen shaft coupling **"H"** from the pump shaft.
  - Loosen the two screws **"G"** for the attachment of the pump in the hydraulic lid.
  - Replace the shaft gasket.
  - Reassemble the pump and shaft coupling. Check that the pumps shaft coupling and the electric motor coupling are fitted in correctly.
- Reassemble the hydraulic lid and valve block.

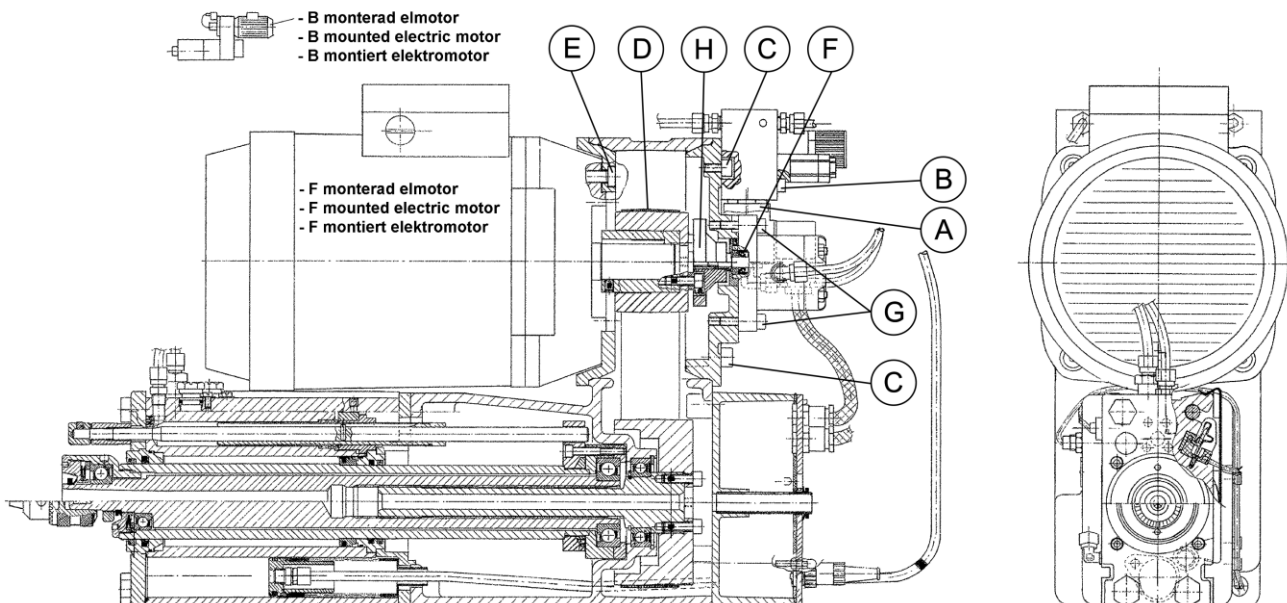

## Hydraulic oil change

Suitable oil quality: Hydraulic oil with a viscosity of e.g 32 cSt at +40° C (+104 F ) and a high viscosity index e.g. 345. Recommended oil: Castrol, Hyspin VG46 SS acc. to ISO VG46.

Oil quantity (filled): Approx. 3 dl (10.56 fl.oz. (UK), 10.14 fl.oz. (US))

Oil refilling equipment: Part no. 040J000038

1. Connect valve "C" incl. the associated hose.
2. Connect hose "D".  
**Important!** Tighten the coupling so that air is not drawn into the hydraulic system.
3. Put the two hose ends in a container with clean hydraulic oil.
4. Unscrew the locking screw "A" and pull the valve sleeve "B" by the help of valve "C".
5. Start the units electric motor and forward run the spindle the whole feed length by pressing the push-button "**CONTRLD FEED**" located on the control system. To return the push-button is released. Repeat this several times for about 1 minute. For oil level see chapter, "Monthly inspection", paragraph 1.
6. Make sure that are no air bubbles in the transparent hoses. In the presence of air bubbles run the spindle back and forth, until the air bubbles have disappeared. When operating the spindle, use the push-buttons located on the units control system.
7. Push in valve sleeve "B" to it's inner operating position and lock it with screw "A".
8. Remove the hoses from the clean hydraulic oil container.
9. Remove valve "C" incl. the associated hose.
10. Loosen the coupling for hose "D" and remove the hose. Tighten the coupling.

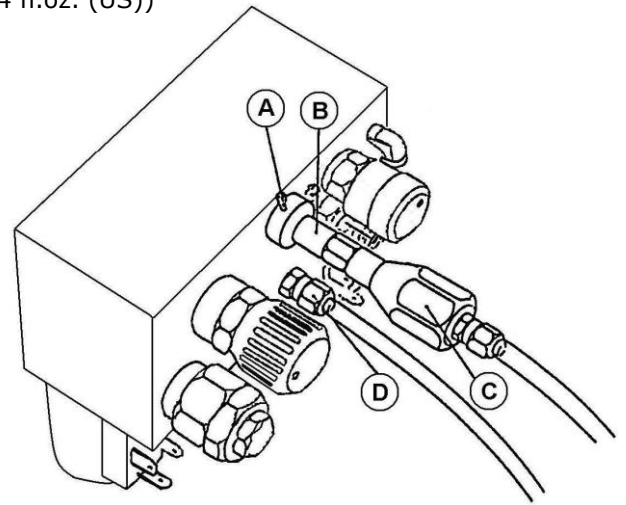

The oil filling is now done.

## Recommended hydraulic oils

Hydraulic oil with good surface adhesion is recommended to prevent "stick-slip". The oil should not only distribute the force – it should also prevent corrosion and wear caused by metal-to-metal contact. Oil with a viscosity which is suitable for the prevailing ambient temperature must be selected. The following table indicates suitable oils for various ambient temperatures, and the equivalent products available. If the viscosity of the oil is higher than recommended, cavitations may occur in the pump.

If the viscosity is lower than recommended, the lubrication will not be sufficient.

Recommended oils:

$$\text{Fahrenheit (F}^\circ\text{)} = \text{Celsius (C}^\circ\text{)} * 1.8 + 32$$

Supplier	Type	Ambient temperature C°.								
		10	15	20	25	30	35	40	45	50
Mobil	Vacuoline 1405 Vacuoline 1409									
Shell	Tonna S32 Tonna S68									
Castrol	Hyspin VG 46SS									
BP	HLP-D 32 HLP-D 46 HLP-D 68									
Texaco	Way Lubricant 68									
Kuwait Oil	Deve									

# Hydraulic diagram and components

Hydraulic diagram 300124

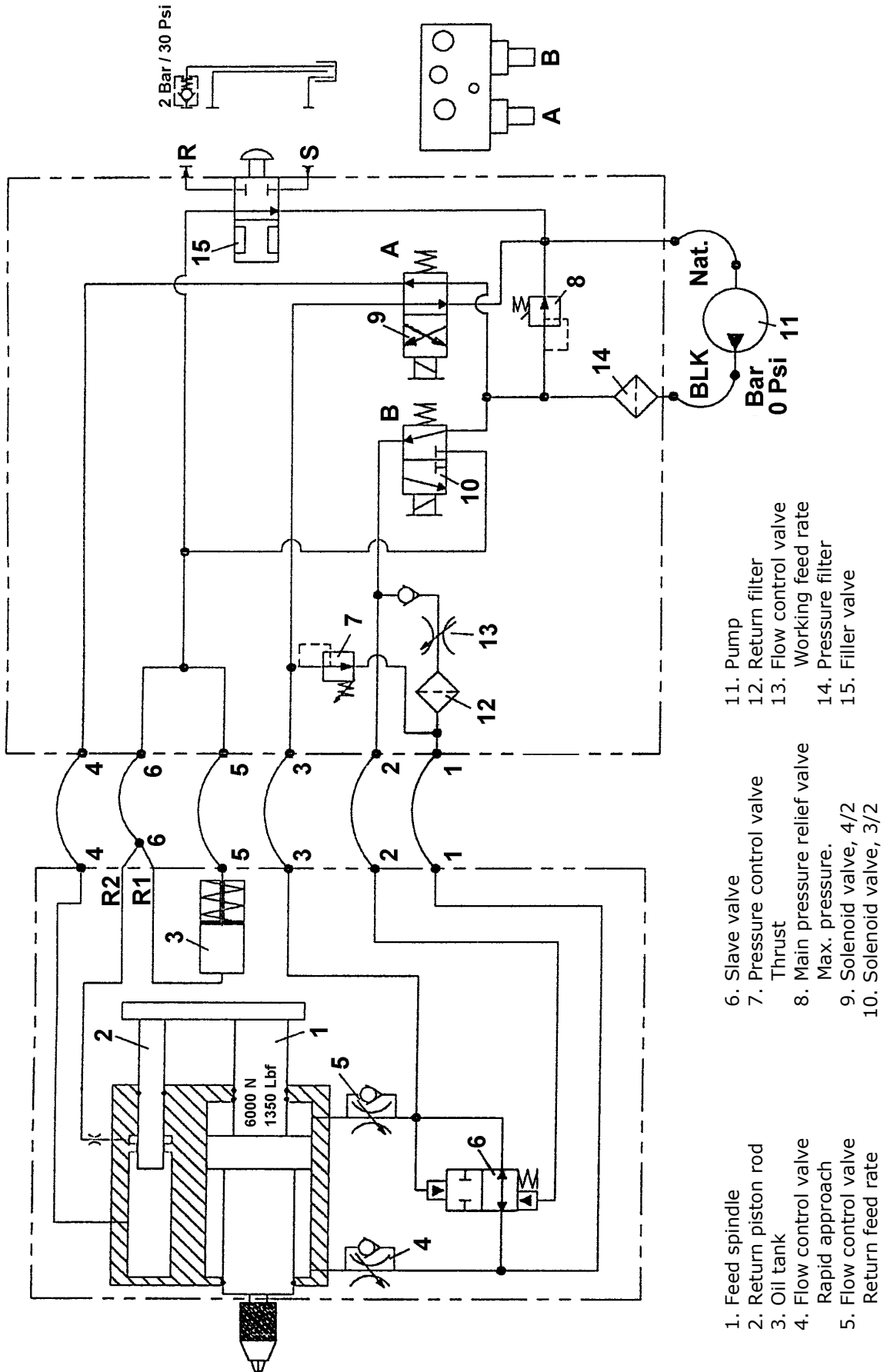

- 1. Feed spindle
- 2. Return piston rod
- 3. Oil tank
- 4. Flow control valve  
Rapid approach
- 5. Flow control valve  
Return feed rate

- 6. Slave valve
- 7. Pressure control valve  
Thrust
- 8. Main pressure relief valve  
Max. pressure.
- 9. Solenoid valve, 4/2
- 10. Solenoid valve, 3/2

- 11. Pump
- 12. Return filter
- 13. Flow control valve  
Working feed rate
- 14. Pressure filter
- 15. Filler valve

## Control card C1:A and wiring diagram

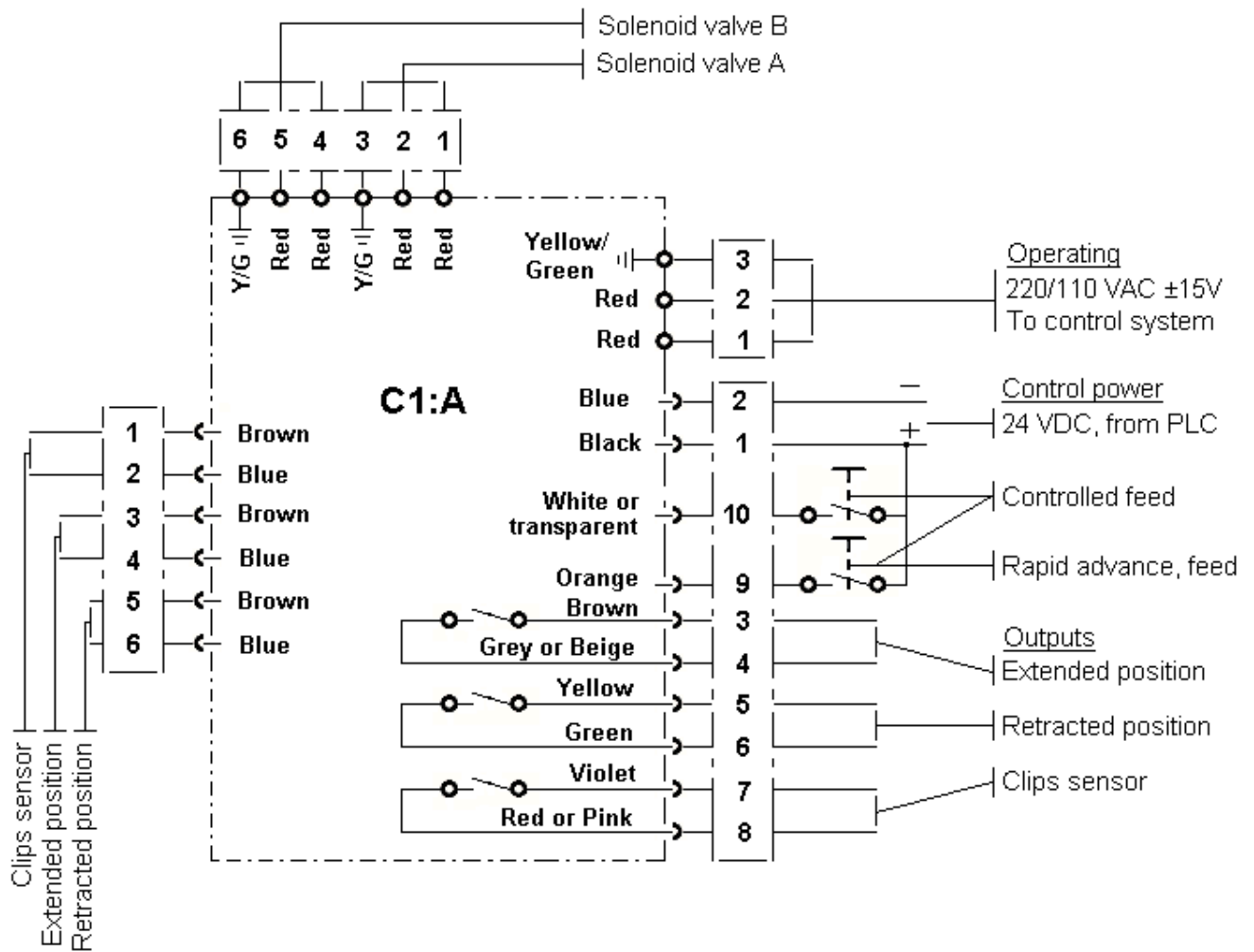



## Technical information

### Technical features:

Thrust	: Max. 6000 N
Stroke	: Max. 120 mm (4 3/4"), 100% controlled.
Min. center to center spacing	: Single spindle min. 140 mm (5 1/2") Double spindle head min. 14 mm (9/16")
Run-out at spindle nose	: MT2, max. 0,03 mm (.0012 In) JT2, max. 0,02 mm (.0008 In)
Depth accuracy	: +/- 0,01 mm (.0004 In)
Rapid advance rate	: Max. 6 m/min (230 In/min)
Controlled feed rate	: > 0,04 – 0,65 m/min (> 1.6 – 25 In/min)
Power, Electric motor	: See Power, Electric motor specifications below.
Ambient temperature	: +10° - +40° C. (+50 - +104 F.)
Sound level	: 80 dB(A)
IP protection	: N/A

### Power, Electric motor specifications:

No. of poles	Unit/Motor at V380-420(Y) / 220-240(Δ) (±5%), 50Hz. kW *		
	BE(G) 552	BE(G) 555	BE(G) 558
2	0,75	1,65	2,7
4	0,55	1,1	2,2
6	0,37	0,75	1,3
8	-	0,4	0,75

\* Motor specifications shown in the tables are valid for 380 – 420V(Y)/220 – 240V(Δ) (±5%), 50 Hz. These motors can also be used at 440 – 480 V(Y) (±5%), 60 Hz. If so the rpm will increase by ~20% and the power by ~15% relative to the data for 50 Hz.

### Transmission specifications:

#### Drilling unit BE 55:

No. of poles	Spindle rpm at gear ratio and 50Hz.								
	2,8:1	2,2:1	1,7:1	1,3:1	1:1	1:1,3	1:1,7	1:2,2	1:2,8
2	1020	1300	1690	2170	2820	3670	4700	6130	7780
4	500	640	830	1070	1390	1810	2320	3020	3830
6	330	420	550	700	910	1180	1520	1980	2510
8	250	310	410	520	680	880	1130	1480	1880

The torque at the spindle for specific rpm is calculated as:  
 $M = (P(\text{kW}) \times 9500) / \text{rpm}$

#### Tapping unit BEG 55:

No. of poles	Spindle rpm at gear ratio and 50Hz.							
	2,7:1	2,1:1	1,7:1	1,4:1	1:1	1:1,4	1:1,7	1:2,1
2	1040	1370	1690					
4	500	640	830	1070	1390	1810		
6	330	420	550	700	910	1180	1520	1980
8	250	310	410	520	680	880	1130	1480

For other data such as drilling capacity we refer to our website [www.e2systems.com](http://www.e2systems.com).

# Dimensional drawing

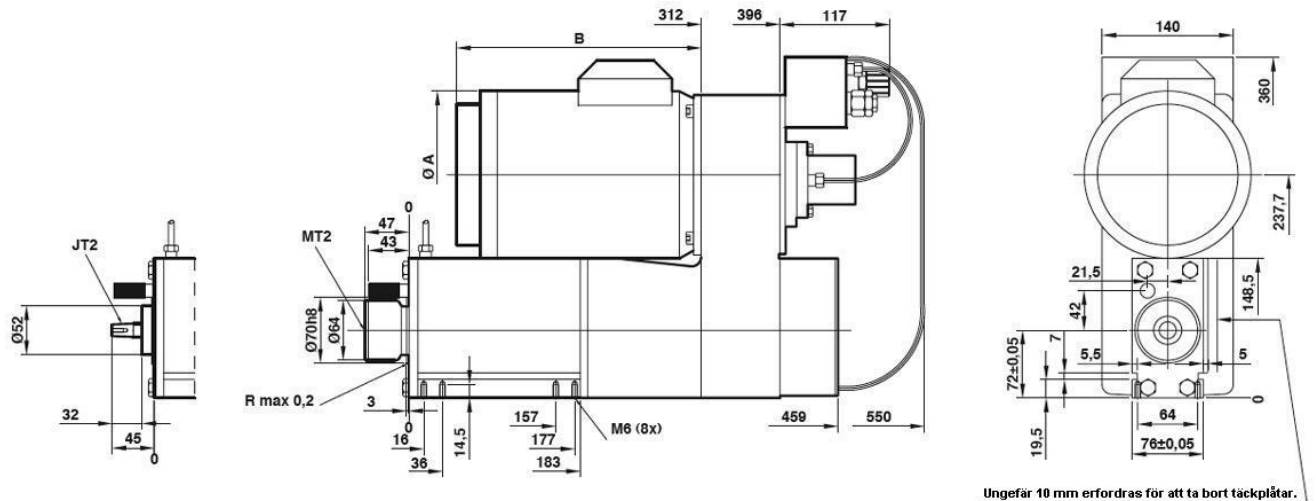

	BE 552/555	BE 558
A	150	178
B	221	261

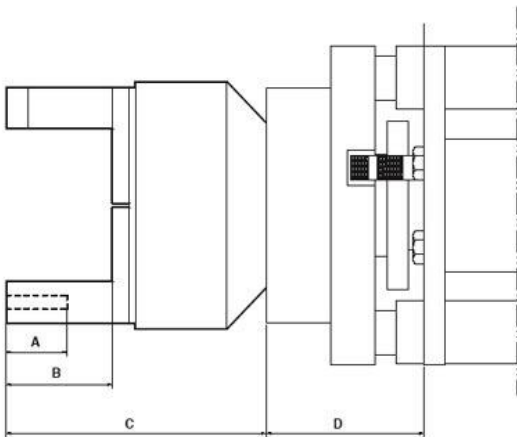
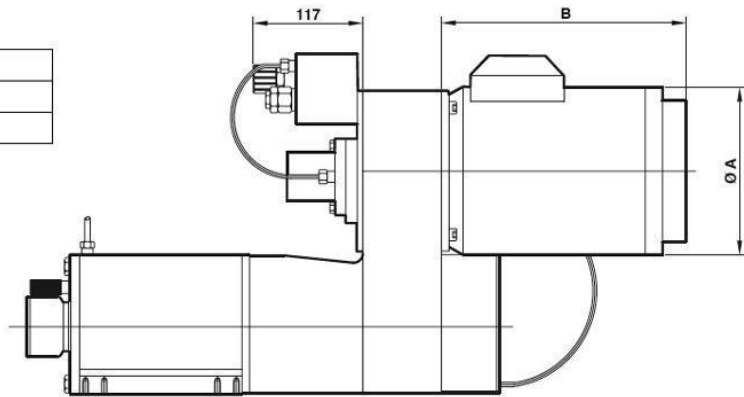

Multi-spindle head, typ	A mm	B mm	C mm	D mm	Adaptor, weight Kgs (Lbs)
<b>MBK-6V2</b>	21	56	117	63	3,1 (6.83)
<b>MBK-6V3 / MBK-6V4</b>	21	56	121	74	3,1 (6.83)
<b>MBK-6VR3</b>	21	56	137	60	3,1 (6.83)
<b>MBKV-602 / 603 / R603 / 604</b>	21	35	127	70	3,1 (6.83)
<b>VH 062P / 063P / 063LP / 064P</b>	25	34	136	63	3,1 (6.83)
<b>MBKV-802 / 803 / R 803 / 804</b>	34	40	144	72	3,1 (6.83)
<b>VH 082P / 083P / 083LP / 084P</b>	28	40	148	63	3,1 (6.83)
<b>MBKV-1002</b>	27	35	163	86	3,1 (6.83)
<b>VH 102P / 103P / 103LP / 104P</b>	28	40	162	68	3,1 (6.83)
<b>MBKV-1302</b>	28-49	55	174	72	3,1 (6.83)
<b>MBKV-1302S / 1303 / R1303 / 1304</b>	20-49	55	174	79	3,1 (6.83)
<b>VH 132P / 133P / 133LP / 134P</b>	28	46	183	68	3,1 (6.83)
<b>MBKV-1402 / 1402S / 1403 / R1403 / 1404</b>	-	94	211	79	3,1 (6.83)
<b>VH 182 / 183 / 183L / 184</b>	-	94	225	68	3,1 (6.83)

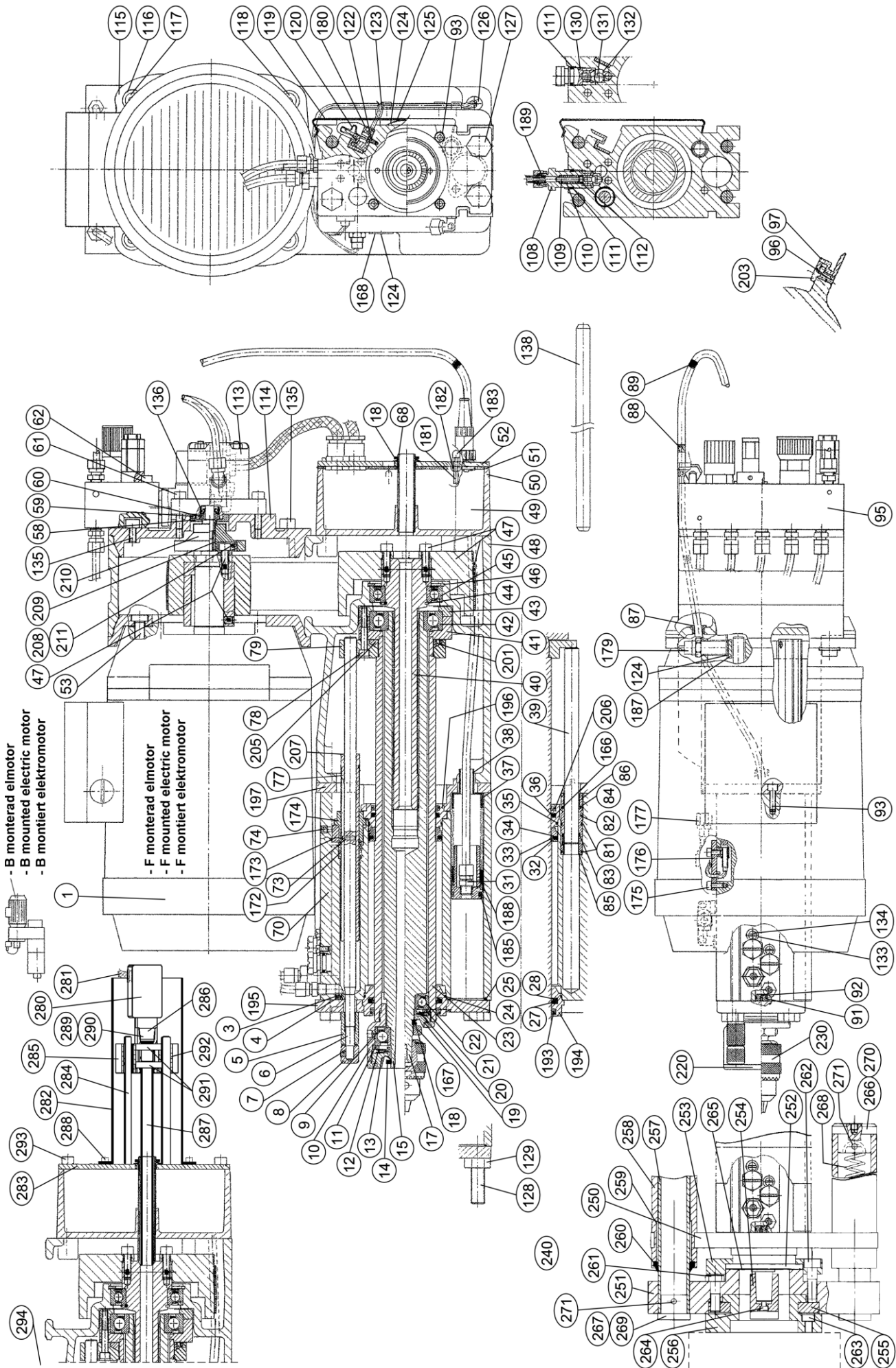

## Spare parts list

<b>BE(G) 552, BE(G) 555 and BE(G) 558</b>			
<b>Pos.</b>	<b>Qty</b>	<b>Description</b>	<b>Part no.</b>
1	1	El. motor, BE(G) 552, 0,75 kW, 2820 Rpm at 50Hz, M2VA 80A	508A000104
1	1	El. motor, BE(G) 555, 1,1 kW, 2820 Rpm at 50Hz, M2VA 80B	508A000105
1	1	El. motor, BE(G) 555, 1,5 kW, 2820 Rpm at 50Hz, M2VA 90S	508A000106
1	1	El. motor, BE(G) 558, 2,7 kW, 2820 Rpm at 50Hz, M2VA 90LB A	508A000108
1	1	El. motor, BE(G) 555, 1,5 kW, 2820 Rpm at 50Hz, M2VA 80C	508A000109
1	1	El. motor, BE(G) 552, 0,55 kW, 1390 Rpm at 50Hz, M2VA 80A	508A000113
1	1	El. motor, BE(G) 552, 0,75 kW, 1390 Rpm at 50Hz, M2VA 80B	508A000114
1	1	El. motor, BE(G) 555, 1,1 kW, 1390 Rpm at 50Hz, M2VA 90S	508A000115
1	1	El. motor, BE(G) 555, 1,5 kW, 1390 Rpm at 50Hz, M2VA 90L	508A000116
1	1	El. motor, BE(G) 555, 1,65 kW, 2820 Rpm at 50Hz, M2VA 80C	508A000123
1	1	El. motor, BE(G) 555, 1,1 kW, 1390 Rpm at 50Hz, M2VA 80C	508A000127
1	1	El. motor, BE(G) 558, 2,2 kW, 1390 Rpm at 50Hz, M2VA 90LB	508A000129
1	1	El. motor, BE(G) 552, 0,37 kW, 910 Rpm at 50Hz, M2VA 80A	508A000132
1	1	El. motor, BE(G) 552, 0,55 kW, 910 Rpm at 50Hz, M2VA 80B	508A000133
1	1	El. motor, BE(G) 558, 0,75 kW, 910 Rpm at 50Hz, M2VA 80S	508A000105
1	1	El. motor, BE(G) 558, 1,1 kW, 910 Rpm at 50Hz, M2VA 90L	508A000135
1	1	El. motor, BE(G) 558, 1,3 kW, 910 Rpm at 50Hz, M2VA 90LB A	508A000136
1	1	El. motor, BE(G) 555, 0,75 kW, 910 Rpm at 50Hz, M2VA 80C	508A000137
1	1	El. motor, BE(G) 558, 0,75 kW, 680 Rpm at 50Hz, M2VA 90LB A	508A000145
1	1	El. motor, BE(G) 552, 0,4 kW, 680 Rpm at 50Hz, M2VA 80C	508A000146
3	4	O-ring, Ø 3,1x1,6 Nitril. See spare parts for Feed housing.	
4	4	O-ring plug	040U000111
5	1	End position nut. See spare parts for Feed housing.	
6	1	End position shaft. See spare parts for Feed housing.	040U000115
7	1	Screw, SK6SS 5x5 black. See spare parts for Feed housing.	
8	1	Knob. See spare parts for Feed housing.	040A000061
9	1	Ball bearing	419A100017
10	1	Bearing holder	040U000099
11	1	Support ring	414A131011
12	4	Spring washer	416A111060
13	1	Spring holder	040U000100
14	1	V-ring	418A230052
15	1	Spindle, with MT2 taper.	040U000096
17	1	Spindle, with JT2 kona.	040U000178
18	1	V-ring	418A230051
19	1	Spring holder	040U000098
20	4	Spring washer	416A111050
21	1	Support ring	414A131010
22	1	Ball bearing	419A100016
23	1	Feed spindle	040U000094
24	1	O-ring, Ø64,2x1,6 Nitril. See spare parts for Feed housing.	
25	1	O-ring, Ø31,4x1,6 Nitril. See spare parts for Feed housing.	
27	1	Gasket, PTFE. See spare parts for Feed housing.	

Pos.	Qty	Description	Part no.
28	1	O-ring, Ø55,56x3,53 Nitril. See spare parts for Feed housing.	
31	1	Coupling B5 6/4-1/8", angled	057B050618
32	1	Feed piston	040U000123
33	1	O-ring, Ø54,6x2,4 Nitril. See spare parts for Feed housing.	
34	1	Piston ring. See spare parts for Feed housing.	
35	1	O-ring, Ø59x1,5 Nitril. See spare parts for Feed housing.	
36	1	Piston rod seal. See spare parts for Feed housing.	
37	1	Pressure spring. See spare parts for Feed housing.	
38	1	Isolation sleeve. See spare parts for Feed housing.	
39	1	Return plunge	040U000116
40	1	Drive shaft. See spare parts for Transmission.	
41	1	Bearing seat. See spare parts for Feed housing.	
42	1	Ball bearing. See spare parts for Feed housing.	
43	1	Bearing retainer. See spare parts for Feed housing.	
44	1	Circlip, SGA 35. See spare parts for Transmission.	
45	1	Ball bearing. See spare parts for Transmission.	
46	1	Circlip, SGH 62. See spare parts for Transmission.	
47	1	Transmission. See spare parts for Transmission.	
48	1	Transmission housing. See spare parts for Transmission.	
49	1	Control card C1:A. See spare parts for Control card C1:A.	
50	1	Electronic box	040U00105
51	1	Flat gasket. On request only.	
52	1	Electronic panel. On request only.	
53	4	Screw, DIN 7984 6x16 black. See spare parts for Transmission.	
57	1	Screw, MC6S 6x50 8.8 FZB	411A121141
58	1	Gasket holder	040U000120
59	3	Screw, S6SS 3x5 black	411A151073
60	1	Spacer ring	040U000121
61	2	Screw, MC6S 6x25 black. See spare parts for Hydraul lid, pump ....	
62	1	Screw, MC6S 6x75 black	411A122040
70	1	Feed housing. See spare parts for Feed housing.	040A000021
73	1	Cylindric pin, Ø3x12 m6. . See spare parts for Feed housing.	
74	1	Screw, P6SS 6x6 black	411A151035
77	1	End position stop. See spare parts for Feed housing.	040U000125
78	3	Screw, MC6S 5x35 FZB. See spare parts for Feed housing.	411A121117
79	1	Dog	040U000126
81	2	O-ring, Ø14,1x1,6 Nitril. See spare parts for Feed housing.	
82	1	Return feed sleeve	040U000187
83	1	O-ring, Ø11,1x1,6 Nitril. See spare parts for Feed housing.	
84	1	X-ring, 10,82x1,78. See spare parts for Feed housing.	
85	1	Slide bearing, PDE	419B200024
86	1	Slide bearing, PDE	419B200023
87	1	Isolation sleeve	418A230093
88	1	Marking sleeve, green	420A000115
89	1	Marking sleeve, red	420A000116
91	1	O-ring, Ø7,1x1,6 Nitril. See spare parts for Feed housing.	
92	1	O-ring plug	040U000110

Pos.	Qty	Description	Part no.
93	6	Screw, MC6S 5x16 FZB. See spare parts for Feed housing.	
95	1	Valve block, complete. See spare parts for Valve block.	
96	1	Screw, DIN 7984 4x18 FZB	411A121017
97	1	Clip ruler. See spare parts for Feed housing.	
108	1	Slave valve sleeve	040U000128
109	1	Slave valve cone	040U000129
110	1	Pressure spring	416A111017
111	3	O-ring, Ø11,3x2,4 Nitril. See spare parts for Feed housing.	
112	1	O-ring, Ø4,1x1,6 Nitril. See spare parts for Feed housing.	
113	1	Hydraulic pump. See spare parts for Hydraul lid, pump ....	
114	1	Hydraul lid. See spare parts for Hydraul lid, pump ....	
115	1	Motor lid, IEC 80. See spare parts for Transmission.	
115	1	Motor lid, IEC 90. See spare parts for Transmission.	
116	4	Tension washer, DIN 6796 8,4x18x2 See spare parts for Transmission.	
117	2	Screw, MC6S 8x25 FZB	411A121152
118	2	Screw, MC6S 8x25 FZB	411A121152
119	1	Protection plate. See spare parts for Feed housing.	
120	4	Shaft coupling body	040U000119
122	1	Screw, MFS 3x8 FZB. See spare parts for Feed housing.	
123	6	Cable clamp. See spare parts for Transmission housing.	
124	6	Screw, KDS 00x3 FZB	415A122001
125	1	Cover plate	040U000181
126	1	Isolation sleeve	418A230093
127	4	Screw, M6S 10x210 FZB. See spare parts for Feed housing.	
128	4	Tie rod	040U000151
129	4	Nut, M6M M10	413A112017
130	2	Throttle-check valve	040U000277
131	2	Ball, Ø6	419A100024
132	2	Spiral pin, N 1x10	415A111029
133	2	Washer, BRB 4,3x10x0,8 FZB. See spare parts for Feed housing.	
134	2	Screw, MC6S 4x8 FZB. See spare parts for Feed housing.	
135	4	Screw, MC6S 8x16 FZB	411A122027
136	1	Radial seal, 8x16x6	418A230091
138	1	Push out rod, for spindle MT2.	040J000002
146	4	Coupling B5 6/4-1/8", angled. See spare parts for Feed housing.	
147	1	Nut, B10 6/4-10x1	057B106400
148	1	Coupling B9 6/4-1/8", T-coupling. See spare parts for Feed housing.	
149	1	Coupling B1 6/4-1/8", rak. See spare parts for Feed housing.	
151	2	Cable strip, 146x3,50 black	420A000021
152	1	Plastic hose, PA12 Ø6/4,0 nature. See spare parts for Feed housing.	
153		Plastic hose, Ø6/3,2 black. See spare parts for Valve block.	
154	1	Label, for control card C1:A. . See spare parts for Control card C1:A.	
155	1	Label, "STROKE DEPTH"	417S900016
156	1	Label, "RETRACT SPEED"	417S900021
157	1	Label, "APPROACH FEED"	417S900025
159	1	Label, "LIMITATION" for Valve block	417S900029
166	2	O-ring, Ø53,64x2,62 Nitril. See spare parts for Feed housing.	



Pos.	Qty	Description	Part no.
167	1	Nut, DIN 439 M16x1,5 FZB	413A112025
168	1	Type label	417S900050
172	1	Pressure spring. See spare parts for Feed housing.	
173	1	Key	040U000142
174	1	End position spindle	040U000143
175	1	Screw, MC6S 4x10 FZB. See spare parts for Feed housing.	
176	1	Front end position sensor, complete. See spare parts for Feed housing.	
179	1	Rear end position sensor, complete. See spare parts for Transmission housing.	
180	1	Clips sensor, complete. . See spare parts for Feed housing.	
181	4	Pin screw, M5x73 2X10. See spare parts for Transmission housing.	
182	1	Nut, M6M M5. See spare parts for Transmission housing.	
183	4	Dome nut, MhM M5 FZB. See spare parts for Transmission housing.	
185	1	Sleeve gasket. . See spare parts for Feed housing.	
187	1	Indication plate	040U000145
188	1	Tank piston. See spare parts for Feed housing..	
189	14	Support sleeve. See spare parts for Valve block.	
193	1	Wiper, PTFE incl. O-ring. See spare parts for Feed housing.	
194	1	Bushing, front end. See spare parts for Feed housing.	
195	1	Front plate, front end. See spare parts for Feed housing.	
196	1	Bushing, rear end. See spare parts for Feed housing.	
197	1	Rear plate, rear end. See spare parts for Feed housing.	
199	2	Cable gland	418A260002
200	1	Cable gland	418A260003
201	1	Screw, S6SS 5x5 black	411A151092
203	1	O-ring, Ø3,0x1,0 Nitril	
205	1	Nut	040U000183
206	1	Wiper, PTFE incl. O-ring. See spare parts for Feed housing.	
207	1	Locking ring, SRA 14	415A151024
208	2	O-ring, Ø12,0x4,0 Nitril	418A210205
209	1	Stop sleeve	040U000288
210	1	Shaft coupling body	040U000225
211	2	Ring	040U000226
220	1	Drill chuck (Albrecht), SBF Ø3,0 – 16,0 mm (.4 – 5/8")MT2	041J004013
220	1	Tapping spindle, GS-24E int. B18 with 40 mm (1 1/2") length compensation.	042J000035
	1	Tap holder T24 for GS-24E. On request. Specify Ø and #.	042J100XXX
220	1	Taper shank, B18/MT2. For 042J000035.	042J000046
230	1	Key chuck JT2 6A-2A, Ø 0 – 13,0 mm (0 – 1/2").	040J000107
	1	Chuck key for the above Key chuck.	041J004073
230	1	Drill chuck JT2, Ø 1,0 – 10,0 mm (.04 – 3/8").	040J000115
230	1	Drill chuck JT2, Ø 1,0 – 13,0 mm (.04 – 1/2").	040J000116
230	1	Drill chuck JT2, Ø 3,0 – 16,0 mm (.04 – 5/8").	040J000117
230	1	Holder for adjustable adjustable adaptor, JT2 TR 20x2	040J000008
230	1	Holder for adjustable adjustable adaptor, JT2 TR 28x2	040J000007
230	1	Collet chuck ER20/JT2, 1 - 15 mm (.04 – 9/16"), for ER20.	040J000123
230	1	Collet. ER20 Ø1,0 – 15,0 mm (.04 – 9/16"). On request.	040J008XXX



Pos.	Qty	Description	Part no.
230	1	Collet chuck ER40/JT2, 21 - 30 mm (13/16 - 1 3/16"), for ER40.	040J000110
230	1	Collet. ER40 Ø21,0 - 30,0 mm (13/16 - 1 3/16"). On request.	041J010XXX
230	1	Tapping spindle, GS-12E int. JT2 with 25 mm (1") length compensation.	042J000034
	1	Tap holder T12 for GS-12E. On request. Specify Ø and #.	042J100XXX
Complete adaptor kits:			
240	1	Adaptor for multi-spindel head MBK 6V2.	040A000500
240	1	Adaptor for multi-spindel heads MBK 600, 6V3, 6V4, VH 06 and VH 08.	040A000501
240	1	Adaptor for multi-spindel heads MBK 800, 1300 and 1400.	040A000502
240	1	Adaptor for multi-spindel heads MBK V 1002.	040A000503
240	1	Adaptor for multi-spindel heads VH 100, VH 130 and VH 180.	040A000504
250	1	End plate	040V300130
251	1	Yoke	040V300131
252	1	Spring holder	040V400299
253	1	Anchor ring	040V400300
254	1	Dog for MBK 6V2, 600, 6V3, 6V4, VH06 and VH08.	040V400309
254	1	Dog for MBK 800, 1300 and 1400.	040V400327
254	1	Dog for MBK V 1002.	040V400219
254	1	Dog for VH 100, VH130 and VH180.	040V400327
254	1	Dog, mid-section for VH 100, VH130 and VH180.	040V300417
255	2	Locking washer	040V400301
256	1	Attachment plate for MBK 6V2.	040V300157
256	1	Attachment plate for MBK 600, 6V3, 6V4, VH 06 and VH 08.	040V300170
256	1	Attachment plate for MBK 800, 1300 and 1400.	040V300152
256	1	Attachment plate for MBK V 1002.	040V300162
256	1	Attachment plate for VH 100, VH 130 and VH 180.	040V300418
257	2	Guide ring	040V400302
258	2	Pillar	040V400304
259	2	Slide bearing, 25x28x30	419B200028
260	2	Wiper, 25x33x4/7	418A230128
261	4	Screw, M6S 8x22 FZB	411A112009
262	4	Screw, MC6S 8x25 FZB	411A121152
263	4	Screw, MC6S 6x25 FZB for MBK 600, 6V3, 6V4, VH 06 and VH 08.	411A122004
263	4	Screw, MC6S 8x25 FZB for MBK 800, 1300 and 1400.	411A121152
263	4	Screw, MC6S 8x16 FZB for MBK V 1002.	411A122027
263	4	Screw, MC6S 8x35 FZB for VH 100, VH 130 and VH 180.	411A121154
264	1	Screw, MC6S 4x16 FZB	411A122016
264	1	Screw, MC6S 4x30 för VH 100, VH 130 and VH 180.	411A122018
265	1	Spacer ring	414A112025
266	2	Protection plug	420A000012
267	2	Protection plug	420A000011
268	2	Pull spring (Only for adaptor with spring return.)	416A111041
269	2	Plug (Only for adaptor with spring return.)	040V400303
270	2	Plug (Only for adaptor with spring return.)	040V400305
271	4	Grooved pin, RPC 4x20 (Only for adaptor with spring return.)	415A111020

<b>Pos.</b>	<b>Qty</b>	<b>Description</b>	<b>Part no.</b>
280	1	Rotary Union	040J100000
281	1	Hydraulic hose, incl. G 3/8 couplings, length = 400 mm (1.31 Ft)	040U000500
282	1	Protection plate	040V300459
283	1	Mid-section plate	040V400726
284	2	Torque bar	040V400727
285	1	Slide plate	040V400728
286	1	Bear coupling	040V400729
287	1	Coolant tube	040V400730
288	2	Screw, DIN 7984 5x10 FZB	411A121018
289	3	Screw, SK6S 4x4 black	411A151199
290	1	O-ring, 6,0x1,0 Nitril	418A210045
291	2	Ball bearing	419A100012
292	4	Bushing	419B000016
293	4	Screw, MC6S M5x75 FZB	411A121181
294	1	Collet chuck ER 32 / MT2, special version.	040J000108
Complete kits:			
1		Spindle, with B12 taper.	040R000014
1		Pilot valve kit, complete.	040R000025
1		Pressure regulating valve, complete.	040R000030
1		Regulating valve, complete.	040R000031
1		Pressure regulating valve for working feed, complete.	040R000032
1		Pressure filter, complete.	040R000033

## Spare parts drawing and Spare parts list

### Feed housing:

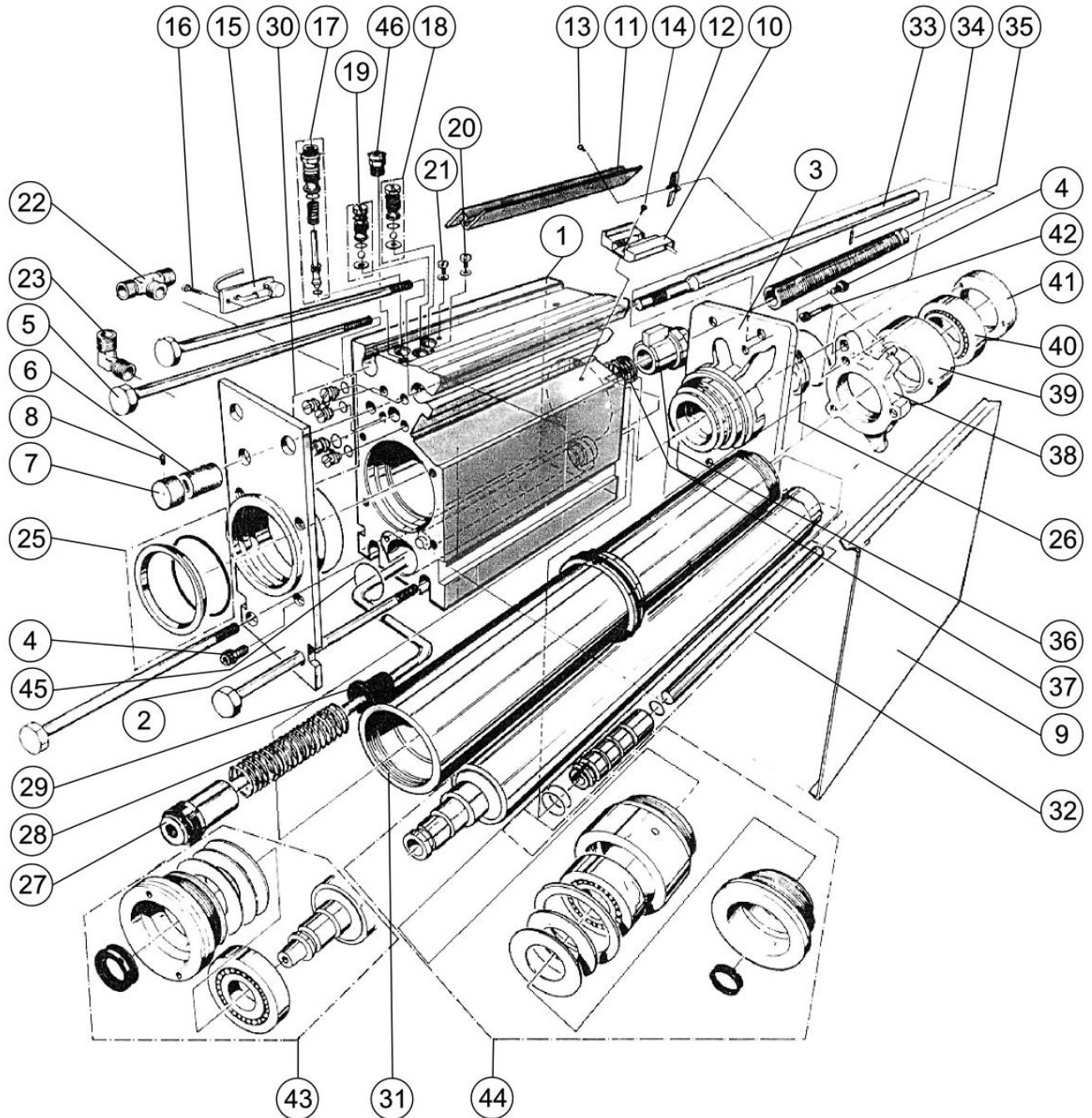

Pos.	Qty	Description	Part no.
1	1	Feed housing	040A000021
2	1	Front plate, front end	040U000173
	1	Bushing, front end	040U000174
3	1	Rear plate, rear end	040U000175
	1	Bushing, rear end	040U000176
4	6	Screw, MC6S 5x16 FZB	411A121114
5	4	Screw, M6S 10x210 FZB	411A111001
6	1	End position nut	040U000114
7	1	Knob	040A000061
8	1	Screw, SK6SS 5x5 black	411A151209
9	1	Protection plate	040U000112

Pos.	Qty	Description	Part no.
10	1	Clips sensor , complete.	040U000162
11	1	Clip ruler	040U000150
12		Clips	040U000149
13	1	Screw, MF6S 3x6 FZB	411A121036
14	1	Screw, MFS 3x8 FZB	411A132007
15	1	Front end position sensor, complete.	040U000161
16	1	Screw, MC6S 4x10 FZB	411A121101
17	1	Slave valve, complete.	Se pos. 50
	1	O-ring, Ø11,3x2,4 Nitril	
	1	O-ring, Ø4,1x1,6 Nitril	
18	1	Throttle-check valve, for approach feed, complete.	Se pos. 51
	1	O-ring, Ø11,3x2,4 Nitril	
19	1	Throttle-check valve, for retract feed, complete.	Se pos. 52
	1	O-ring, Ø11,3x2,4 Nitril	
20	2	Washer, BRB4,3X10X0,8 FZB	414A122004
21	2	Screw, MFS 4x8 FZB	411A132015
22	1	Coupling B9 6/4-1/8", T-coupling	057B096400
23	3	Coupling B5 6/4-1/8", angled	057B050618
24	1	Coupling B1 6/4-1/8", staright	057B010618
25	1	Seal kit, for front end, complete.	Se pos. 53
26	1	Seal kit, for rear end, complete.	Se pos. 54
27	1	Tank piston, complete.	Se pos. 55
28	1	Pressure spring	416A111019
29	1	Isolation sleeve	418A230094
30	1	Plug kit, complete.	Se pos. 56
31	1	Feed spindle, complete.	040U000180
	1	Piston ring	
	1	O-ring, Ø54,6x2,4 Nitril	
32	1	Retract feed sleeve, complete.	Se pos. 57
	2	O-ring, Ø14,1x1,6 Nitril	
	1	O-ring, Ø11,1x1,6 Nitril	
	1	X-ring, 10,82x1,78	
33	1	End position shaft	040U000115
34	1	Cylindric pin, Ø3x12 m6	415A111013
35	1	End position stop	040U000125
36	1	End position spindle, complete.	Se pos. 58
37	1	Pressure spring	416A111018
38	1	Dog, complete.	Se pos. 59
39	1	Bearing seat	040U000113
40	1	Ball bearing	419A100018
41	1	Bearing retainer	040U000117
42	3	Screw, MC6S 5x35 FZB	411A121117
43	1	Spindle kit, for JT2 taper, complete.	Se pos. 60
44	1	Spindle kit, for MT2 taper, complete.	Se pos. 61
45	1	O-ring, Ø31,4x1,6 Nitril	418A210066
46	1	Coupling B1 6/4-1/8", straight	057B010618

<b>Pos.</b>	<b>Qty</b>	<b>Description</b>	<b>Part no.</b>
Complete kits:			
50	1	Slave valve, complete.	040R000027
51	1	Throttle-check valve, for approach feed, complete.	040R000028
52	1	Throttle-check valve, for retract feed, complete.	040R000028
53	1	Seal kit, for front end, complete.	040R000012
54	1	Seal kit, for rear end, complete.	040R000013
55	1	Tank piston, complete.	040R000034
56	1	Plug kit, complete.	040R000035
57	1	Retract feed sleeve, complete.	040R000036
58	1	End position spindle, complete.	040R000039
59	1	Dog, complete.	040R000037
60	1	Spindle kit, for JT2 taper, complete.	040R000016
61	1	Spindle kit, for MT2 taper, complete.	040R000015
62	1	Seal kit, for feed housing, complete.	040R000001

## Spare parts drawing and Spare parts list

### Hydraul lid, pump and coupling:

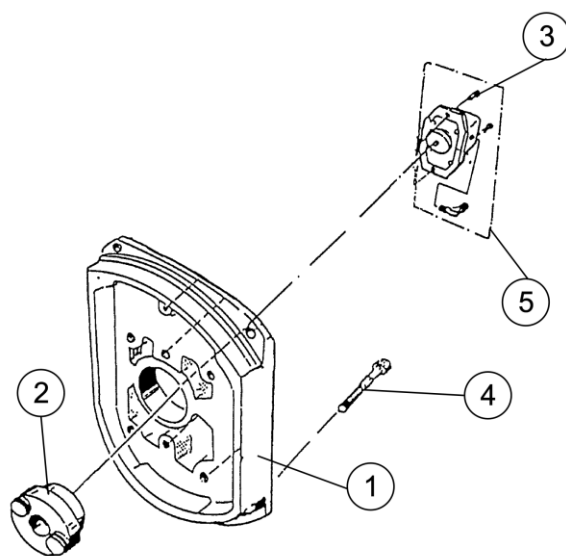

Pos.	Qty	Description	Part no.
1	1	Hydraul lid	040A000033
2	2	Screw, MC6S 6 x 25 black	411A121137
3	4	Screw, MC6S 8 x 20 black	411A121004
4	1	Hydraulic pump, for 2-pole el. motor with 2800 rpm, complete. *)	040R000044
4	1	Hydraulic pump, for 4-pole el. motor with 1400 rpm, complete. *)	040R000045
4	1	Hydraulic pump, for 6-pole el. motor with 900 rpm, complete. *)	040R000046
4	1	Hydraulic pump, for 8-pole el. motor with 700 rpm., complete. *)	040R000047
Complete kits:			
5	1	Pump coupling, complete	040R000042

\*) Reversible hydraulic pump that is suitable for all types of electric motors.

Connections to connect the drainage outlet to the pump with the hose to the tank piston is included.

- Cut off the hose to the tank piston and connect the T-coupling.

## Spare parts drawing and Spare parts list

### Valve block:

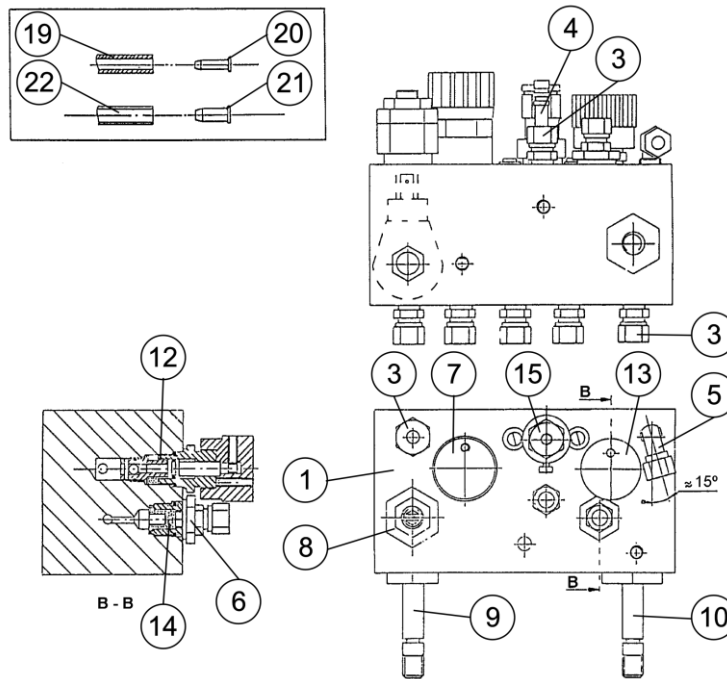

Pos.	Qty	Description	Part no.
1	1	Valve block assembly excl. valves	Se pos. 25
3	8	Coupling B1 6/4-1/8", rak	057B010618
4	1	Plugg	057E090600
5	1	Coupling B5 6/4-1/8", vinklad	057B050618
6	1	Filter nipple	040V400095
7	1	Pressure regulating valve	040A000072
8	1	Pressure regulating valve	040A000071
9	1	Directional control valve, 4/2	040A000074
10	1	Directional control valve, 3/2	040A000073
11	2	Magnetic coil, 220 VAC 50 Hz	040A000075
11	2	Magnetic coil, 110 VAC 60 Hz	040A000076
12	1	Return filter	040U000082
13	1	Flow control valve, complete.	Se pos. 26
14	1	Pressure filter	040U000083
15	1	Oil refilling valve, complete.	Se pos. 27
19	1	Plastic hose PA12, Ø6/3,2 mm black	057G000026
20	10	Support sleeve, Ø6/3,2	040U000109
21	4	Support sleeve, Ø6/4 mm	057B126400
22	1	Plastic hose PA12, Ø6/4 mm natur	057G000023
Complete kits:			
25	1	Valve block assembly excl. valves	040R000061
26	1	Flow control valve, complete.	040R000062
27	1	Oil refilling valve, complete.	040R000063
26	1	Valve block assembly for 220 VAC, complete.	040S100002
27	1	Valve block assembly for 110 VAC, complete.	040S100003
28	1	Seal kit for valve block, complete.	040R000060
	1	Solenoid valve kit for 220 VAC 50 Hz, complete	040R000040
	1	Solenoid valve kit for 110 VAC 60 Hz, complete	040R000041



## Spare parts drawing and Spare parts list

Transmission for F- and B-mounted electric motor IEC 80 and IEC 90 with flat drive belt:  
Transmission for F- and B-mounted electric motor IEC 80 and IEC 90 with toothed drive belt.

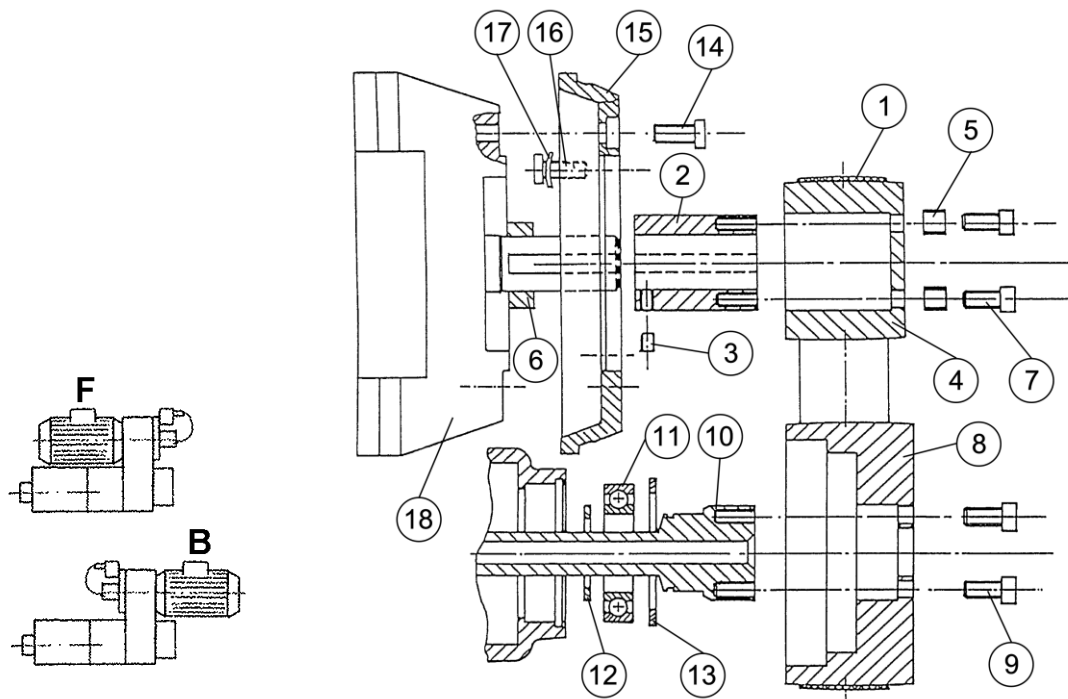

Flat drive belt for BE 552, BE 555 and BE 558.

Type of motor:	Ratio:	Pos. 1 Drive belt	Pos. 2 Hub	Pos. 3 Screw	Pos. 4 Pulley	
IEC 80 "F"	2,76:1	040U000006	040U000033	411A151266	-	
	2,17:1	040U000006	040U000036	411A151266	-	
	1,67:1	040U000006	040U000033	411A151266	040U000026	
	1,3:1	040U000005	040U000034	411A151266	040U000029	
	1:1	040U000003	040U000032	411A151266	040U000029	
	0,77:1	040U000005	040U000032	411A151266	040U000030	
	0,6:1	040U000004	040U000032	411A151266	040U000030	
	0,46:1	040U000002	040U000032	411A151266	040U000030	
	0,36:1	040U000001	040U000032	411A151266	040U000030	
			<b>Pos. 5 Spacer</b>	<b>Pos. 7 Screw</b>	<b>Pos. 8 Pulley</b>	<b>Transmission kit, complete.</b>
	2,76:1	040U000131	411A121088	040U000022	040A000136	
	2,17:1	040U000131	411A121088	040U000022	040A000135	
	1,67:1	040U000130	411A121088	040U000022	040A000134	
	1,3:1	040U000132	411A121011	040U000021	040A000133	
	1:1	-	411A121087	040U000029	040A000132	
	0,77:1	-	411A121087	040U000029	040A000131	
	0,6:1	-	411A121087	040U000028	040A000130	
	0,46:1	-	411A121087	040U000027	040A000129	
	0,36:1	-	411A121087	-	040A000128	

Type of motor:	Ratio:	Pos. 1	Pos. 2	Pos. 3	Pos. 4	
		Drive belt	Hub	Screw	Pulley	
IEC 80 "B"	2,76:1	040U000006	040U000033	411A151266	-	
	2,17:1	040U000007	040U000036	411A151266	-	
	1,67:1	040U000008	040U000033	411A151266	040U000026	
	1,3:1	040U000005	040U000034	411A151266	040U000029	
	1:1	040U000003	040U000034	411A151266	040U000029	
	0,77:1	040U000009	040U000034	411A151266	040U000030	
	0,6:1	040U000004	040U000034	411A151266	040U000030	
	0,46:1	040U000002	040U000034	411A151266	040U000030	
	0,36:1	040U000001	040U000034	411A151266	040U000030	
		Pos. 5	Pos. 7	Pos. 8	Transmission kit, complete.	
	Ratio:	Spacer	Screw	Pulley		
		2,76:1	040U000131	411A121088	040U000022	040A000127
		2,17:1	040U000131	411A121088	040U000022	040A000126
		1,67:1	040U000130	411A121088	040U000022	040A000125
		1,3:1	040U000132	411A121011	040U000021	040A000124
		1:1	040U000132	411A121087	040U000029	040A000123
		0,77:1	040U000132	411A121087	040U000029	040A000122
		0,6:1	040U000132	411A121087	040U000028	040A000121
		0,46:1	040U000132	411A121088	040U000027	040A000120
		0,36:1	040U000132	411A121087	-	040A000119

Type of motor:	Ratio:	Pos. 1	Pos. 2	Pos. 3	Pos. 4	
		Drive belt	Hub	Screw	Pulley	
IEC 90 "F/B"	2,76:1	040U000012	040U000020	411A151266	-	
	2,17:1	040U000013	040U000035	411A151266	-	
	1,67:1	040U000011	040U000031	411A151266	040U000026	
	1,3:1	040U000009	040U000031	411A151266	040U000025	
	1:1	040U000010	040U000031	411A151266	040U000024	
		Pos. 5	Pos. 7	Pos. 8	Transmission kit, complete.	
	Ratio:	Spacer	Screw	Pulley		
		2,76:1	-	411A121087	040U000023	040A000141
		2,17:1	-	411A121087	040U000023	040A000140
		1,67:1	4x 414A112031	411A121087	040U000023	040A000139
		1,3:1	4x 414A112031	411A121087	040U000023	040A000138
		1:1	4x 414A112031	411A121087	040U000023	040A000137

**Toothed drive belt for BE 552, BE 555 and BE 558.**

Type of motor:		Pos. 1	Pos. 2	Pos. 3	Pos. 4
	Ratio:	Drive belt	Hub	Screw	Pulley
IEC 80 "F"	2,05:1	422A000002	040U000032	411A151266	040V400154
	1,72:1	422A000001	040U000032	411A151266	040V400286
	1,38:1	422A000003	040U000032	411A151266	040V300112
	1:1	422A000004	040U000032	411A151266	040V300080
	0,72:1	422A000005	040U000032	411A151266	040V300050
	0,58:1	422A000006	040U000032	411A151266	040V300058
		Pos. 5	Pos. 6	Pos. 7	Pos. 8
	Ratio:	Spacer	Spacer	Screw	Pulley
	2,05:1	-	-	2x 411A121087	040V300065
	1,72:1	-	-	2x 411A121087	040V300058
	1,38:1	-	-	2x 411A121087	040V300065
	1:1	-	-	2x 411A121087	040V300065
	0,72:1	-	-	2x 411A121087	040V300049
	0,58:1	-	-	2x 411A121087	040V300057

Type of motor:		Pos. 1	Pos. 2	Pos. 3	Pos. 4
	Ratio:	Drive belt	Hub	Screw	Pulley
IEC 80 "B"	2,05:1	422A000002	040U000034	411A151266	040V400154
	1,72:1	422A000001	040U000034	411A151266	040V400286
	1,38:1	422A000003	040U000034	411A151266	040V300112
	1:1	422A000004	040U000034	411A151266	040V300080
		Pos. 5	Pos. 6	Pos. 7	Pos. 8
	Ratio:	Spacer	Spacer	Screw	Pulley
	2,05:1	040V400292	040V400288	2x 411A121140	040V300065
	1,72:1	040V400292	040V400288	2x 411A121140	040V300058
	1,38:1	040V400292	040V400288	2x 411A121140	040V300065
	1:1	040V400292	040V400288	2x 411A121140	040V300065

**Toothed drive belt for BE 552, BE 555 and BE 558.**

Type of motor:	Ratio:	Pos. 1 Drive belt	Pos. 2 Hub	Pos. 3 Screw	Pos. 4 Pulley
IEC 90 "F"	2,05:1	422A000002	040U000031	411A151266	040V400154
	1,72:1	422A000001	040U000031	411A151266	040V400286
	1,38:1	422A000003	040U000031	411A151266	040V300112
	1:1	422A000004	040U000031	411A151266	040V300080
	0,72:1	422A000005	040U000031	411A151266	040V300050
	0,58:1	422A000006	040U000031	411A151266	040V300058
		Pos. 5	Pos. 6	Pos. 7	Pos. 8
	Ratio:	Spacer	Spacer	Screw	Pulley
	2,05:1	4x...414A112031	-	2x 411A121087	040V300065
	1,72:1	4x...414A112031	-	2x 411A121087	040V300058
	1,38:1	4x...414A112031	-	2x 411A121087	040V300065
	1:1	4x...414A112031	-	2x 411A121087	040V300065
	0,72:1	4x...414A112031	-	2x 411A121087	040V300049
	0,58:1	4x...414A112031	-	2x 411A121087	040V300057

Type of motor:	Ratio:	Pos. 1 Drive belt	Pos. 2 Hub	Pos. 3 Screw	Pos. 4 Pulley
IEC 90 "B"	2,05:1	422A000002	040U000034	411A151266	040V400154
	1,72:1	422A000001	040U000034	411A151266	040V400286
	1,38	422A000003	040U000034	411A151266	040V300112
	1:1	422A000004	040U000034	411A151266	040V300080
		Pos. 5	Pos. 6	Pos. 7	Pos. 8
	Ratio:	Spacer	Spacer	Screw	Pulley
	2,05:1	4x...414A112031	-	2x 411A121087	040V300065
	1,72:1	040V400292	-	2x 411A121087	040V300058
	1,38	4x...414A112031	-	2x 411A121087	040V300065
	1:1	4x...414A112031	-	2x 411A121087	040V300065

Pos.	Qty	Description	Part no.
9		Screw, MC6S 6x20	411A121087
10	1	Drive shaft	040U000122
11	1	Ball beraing	419A100015
12	1	Circlip, SGA 35	415A151003
13	1	Circlip, SGH 62	415A151019
14		Screw, DIN 7984 6x16 black	411A121024
15	1	Motor lid, IEC 80	040A000029
15	1	Motor lid, IEC 90	040A000031
16		Screw, DIN 7984 8x25 FZB	411A121028
17		Tension washer, DIN 6796 8,4x18x2	414A121030

## Spare parts drawing and Spare parts list

Transmission for F-/B-mounted electric motor IEC 80 and IEC 90 with toothed drive belt.

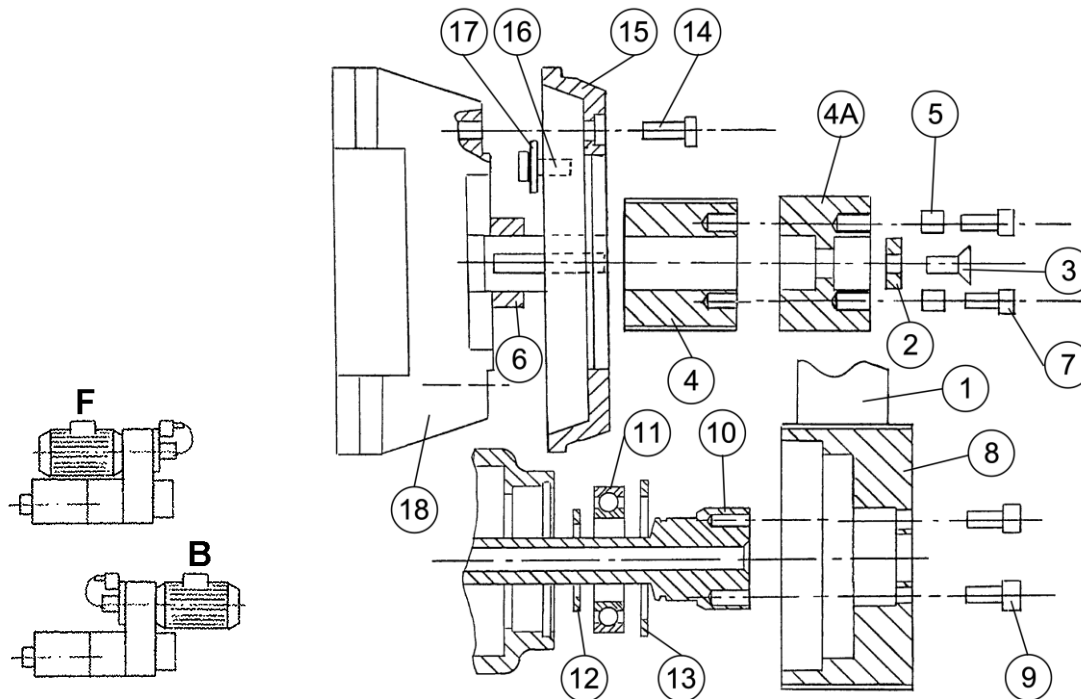

Toothed drive belt for BE 552, BE 555 and BE 558.

Type of motor:	Ratio:	Pos. 1 Drive belt	Pos. 2 Washer	Pos. 3 Screw	Pos. 4 Pulley
IEC 80 "F/B"	2,71:1	422A000001	040V400157	411A121062	040V400289
	Ratio:	Pos. 5 Spacer	Pos. 6 Spacer	Pos. 7 Screw	Pos. 8 Pulley
	2,71:1	040U000131	-	2x 411A122005	040V300065

Type of motor:	Ratio:	Pos. 1 Drive belt	Pos. 2 Washer	Pos. 3 Screw	Pos. 4 Pulley	Pos. 4A Clutch
IEC 90 "F/B"	2,71:1	422A000001	040V400157	411A121062	040V400289	040V400159
	Ratio:	Pos. 5 Spacer	Pos. 6 Spacer	Pos. 7 Screw	Pos. 8 Pulley	Pos. 8 Pulley
	2,71:1	-	040V400156	2x 411A122024	040V300065	040V300065

Pos.	Qty	Description	Part no.
9		Screw, MC6S 6x20	411A121087
10	1	Drive shaft	040U000122
11	1	Ball beraing	419A100015
12	1	Circlip, SGA 35	415A151003
13	1	Circlip, SGH 62	415A151019
14		Screw, DIN 7984 6x16 black	411A121024
15	1	Motor lid, IEC 90	040A000031
16		Screw, DIN 7984 8x25 FZB	411A121028
17		Tension washer, DIN 6796 8,4x18x2	414A121030

## Spare parts drawing and Spare parts list

### Transmission housing:

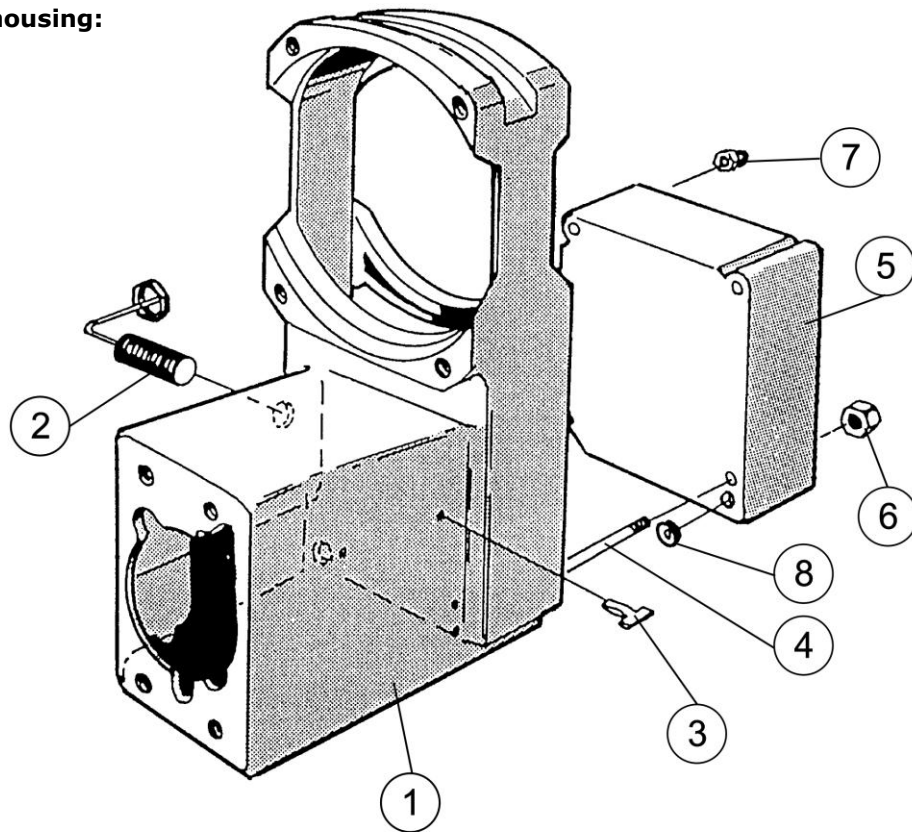

Pos.	Qty	Description	Part no.
1	1	Transmission housing	040A000025
2	1	Rear end position sensor, complete.	040U000191
3	5	Cable clamp	420A000120
4	4	Pin screw, M5x73 2X10	040U000144
5	1	Electronic box, complete.	040U000105
6	2	Nut, M6M M5 FZB	413A112014
7	4	Dome nut, MhM M5 FZB	413A112031
Complete kits:			
1	1	Cable gland kit, complete.	040R000024

## Spare parts drawing and Spare parts list

### Control card C1:A.

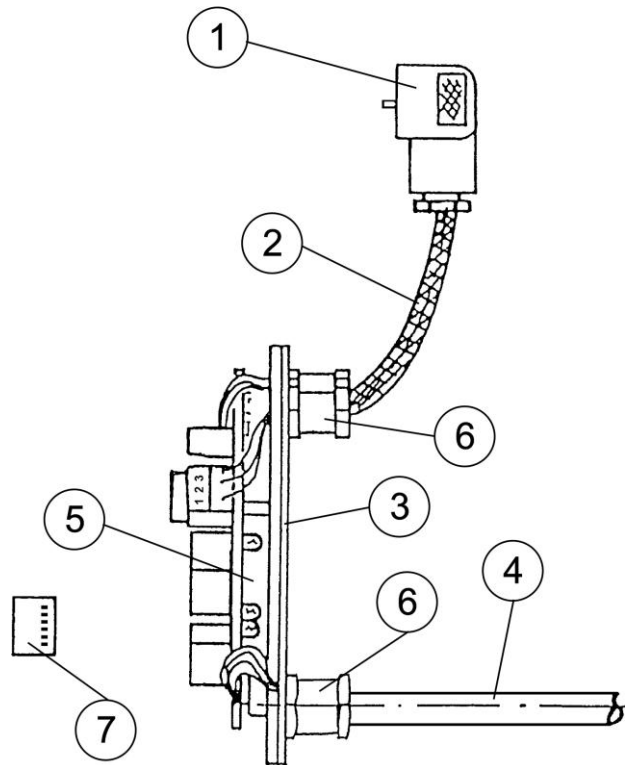

Pos.	Qty	Description	Part no.
1	2	Plug, PG9	028J000101
2	2	Cable, 3x0,75, L = 0,5 meter (1.64 Ft)	514A000002
3	1	Label, for control card.	417S900013
4	1	Cable, CY 10x0,34, L = 1,5 meter (4.92 Ft)	514A000005
Complete Kits:			
5	1	Control card C1:A, complete.	040U000235
6	1	Cable gland kit, complete.	040R000024
7	1	Connector, incl. crimp contacts, complete.	040R000055



## Warranty conditions

The warranty period for the product is 4 000 000 cycles or 12 months after installation/commissioning or 18 months after delivery, whichever of these occurs first, and provided that the product is installed/stored in a satisfactory manner and that the product is used in normal operation, the mounting/clamping and handling conditions. The warranty is not valid if unauthorized change/modification have been performed on the product and that this may make the product unsafe.

## Environmental declaration

Unit, Type BE 552 , BE 555, BE 558 or BEG 552, BEG 555, BEG 558.

Housing	: Aluminium
Pinole	: Brass
Electric motor	: Aluminium, steel and copper.
Other parts	: Aluminium, brass and steel.
Seals, Drive belt	: Rubber, Rubber/steel
Hydraulic oil	: Oil. The unit contains a small amount of hydraulic oil.

Housing, pinole and other metallic parts	: Dispose as metal waste; Aluminium, brass and steel.
Electric motor	: Dispose as electric waste.
Seals, Drive belt	: Dispose as combustible waste.
Hydraulic oil	: Dispose as hazardous waste.

---

All information contained in this manual is intended to be correct; however information and data in this manual are subject to change without notice. E2systems makes no warranty of any kind of regard to this information or data. Further, E2systems is not responsible for any omissions or errors or consequential damaged caused by the user of the product. E2systems reserves the right to make manufacturing changes which may not be included in this manual.